

## **Statische Berechnung**

### **Genehmigungsplanung LPh 4**

**PROJEKT-NR.:**           **6168**

---

**BAUHERR:**               **AluTeck**

**BAUVORHABEN:**       **Aluminium Dielenbelag AluTeck 40G**

---

**aufgestellt:**             **21.05.2024/ Ki**



**Inhaltsverzeichnis**

**1.0 Vorbemerkungen**

---

1.0 Vorbemerkungen.....	Seite: 1-001
1.1 Lastannahmen.....	Seite: 1-002
1.2 Geometrie Dielenprofil.....	Seite: 1-003

**2.0 Einfeldträger**

---

2.0 Einfeldträger.....	Seite: 2-001
2.1 Einfeldträger l = 2,15m.....	Seite: 2-002
2.2 Einfeldträger l = 2,15m mit Kragarm.....	Seite: 2-006

**3.0 Zweifeldträger**

---

3.0 Zweifeldträger l = 2,45m.....	Seite: 3-001
-----------------------------------	--------------

**4.0 Dreifeldträger**

---

4.0 Dreifeldträger l = 2,45m.....	Seite: 4-001
-----------------------------------	--------------

**Schlussblatt**

---

Schlussblatt.....	Seite: 5-001
-------------------	--------------



## 1.0 Vorbemerkungen

### Normen:

DIN EN 1990 +NA Grundlagen  
DIN EN 1991-1 +NA Einwirkungen  
DIN EN 1999-1 +NA Aluminiumtragwerke

### Material:

Aluminium AW 6063 T66

### Software:

Dlubal RStab 8.32  
Dlubal DUENQ 8  
Frilo

### Allgemeines:

Die vorliegende Statische Berechnung erbringt den Nachweis für den Dielenbelag

**AluTeck 40G**

für

**AluTeck  
77966 Kappel-Grafenhausen**

Die genauen Abmessungen der hier nachgewiesenen Konstruktion sind der zu dieser Berechnung gehörenden Konstruktionszeichnung zu entnehmen.



### **1.1 Lastannahmen:**

Lasten auf Balkondielen

Eigengewicht aus EDV

Nutzlast  $p = 4,0 \text{ kN/m}^2$



## 1.2 Geometrie Dielenprofil

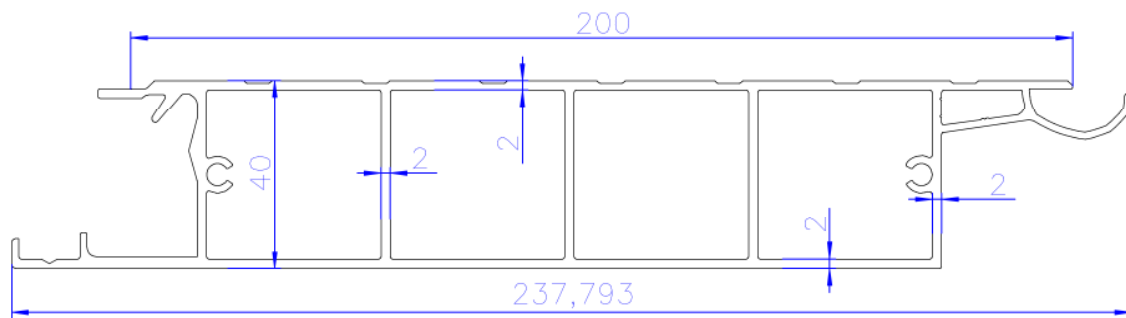

Werkstoff: Aluminium AW 6063 T66

Ermittlung Querschnittswerte mit Dlubal DUENQ  
s. EDV-Ausdruck



### MODELL-BASISANGABEN

Querschnittsname Positive Orientierung der Y-Achse	AluTeck40G Rechts
Zusätzlich berechnen Plastische Querschnittswerte (ohne kombinierte Belastungsbedingungen) c/t-Teile und wirksame Querschnittswerte Nachweis der plastischen Tragfähigkeit (mit kombinierten Belastungsbedingungen)	Nein Nein Nein
Globale Berechnungsparameter Interne Teilungen für die Berechnung Elemente Gekrümmte Elemente Punktelemente Position der auf die Querschnittsgeometrie bezogenen Hauptachsen bei der Drehung des Querschnitts behalten Spannungen ermitteln für Referenzmaterial Schubspannungen an Nullelementen  Berechnung der Vergleichsspannungen $\sigma_v$ Sich überlappende Elemente in der Berechnung nur einmal berücksichtigen Hauptachsen transformieren, dass $I_y$ (mittlere Achse) immer größer als $I_x$ (angrenzende Achse) ist Schnittgrößen bezogen auf Berechnung des Torsionsträgheitsmomentes $I_t$ Korrekturbeiwert Gebundene Drillachse Knicklinien zuweisen Achsen y/u Achsen z/v Standard-Korrelationsbeiwert Teilsicherheitsbeiwert Referenzmaterial	20 15 50 Nein  Ungünstigste Element-Kanten Aluminium EN-AW 6063 (DT) T66   EN 1999-1-1:2007 Umverteilung der Schubspannungen von Nullelementen an normale Elemente Von Mises Ja  Nein  Hauptachsen u,v Analytisch $\eta = 1.00$ Nein  c c $\beta_w = 1.00$ $\gamma_{M2} = 1.25$ Aluminium EN-AW 6063 (DT) T66   EN 1999-1-1:2007

### MODELL

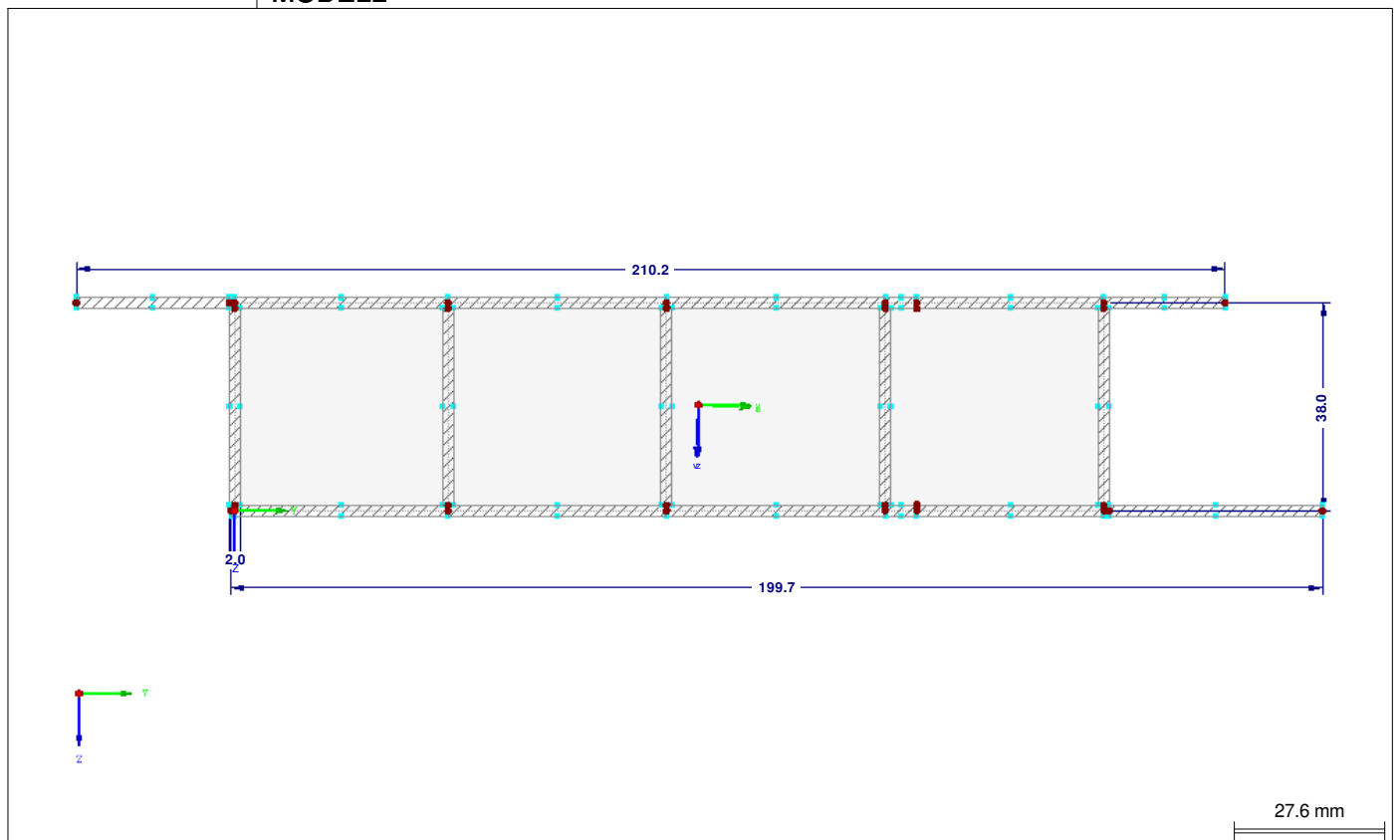

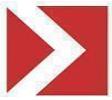

Projekt: AluTeck40G Modell: AluTeck40G Datum: 21.05.2024

## 1.1 KNOTEN

Knoten Nr.	Koordinatensystem	Bezugs-Knoten	Knotenkoordinaten		u [mm]		v [mm]		Kommentar
			Y [mm]	Z [mm]					
1	Kartesisch	-	-0.7	0.0	-84.6	23.3			
2	Kartesisch	-	199.0	0.0	114.9	14.0			
3	Kartesisch	-	-29.0	-38.0	-114.6	-13.3			
4	Kartesisch	-	181.2	-38.0	95.4	-23.1			
5	Kartesisch	-	160.0	0.0	76.0	15.8			
6	Kartesisch	-	39.0	0.0	-44.9	21.5			
7	Kartesisch	-	79.0	0.0	-4.9	19.6			
8	Kartesisch	-	119.0	0.0	35.0	17.7			
9	Kartesisch	-	124.8	0.0	40.8	17.5			
10	Kartesisch	-	-1.0	-38.0	-86.6	-14.6			
11	Kartesisch	-	39.0	-38.0	-46.7	-16.5			
12	Kartesisch	-	79.0	-38.0	-6.7	-18.4			
13	Kartesisch	-	119.0	-38.0	33.2	-20.2			
14	Kartesisch	-	124.8	-38.0	39.0	-20.5			
15	Kartesisch	-	0.0	0.0	-83.9	23.3			
16	Kartesisch	-	0.0	-38.0	-85.6	-14.7			
17	Kartesisch	-	159.0	0.0	75.0	15.9			
18	Kartesisch	-	159.0	-38.0	73.2	-22.1			
19	Kartesisch	-	0.0	-37.0	-85.6	-13.7			
20	Kartesisch	-	39.0	-1.0	-44.9	20.5			
21	Kartesisch	-	39.0	-37.0	-46.6	-15.5			
22	Kartesisch	-	0.0	-1.0	-83.9	22.3			
23	Kartesisch	-	84.8	-19.3	0.0	0.0			
24	Kartesisch	-	79.0	-1.0	-5.0	18.6			
25	Kartesisch	-	79.0	-37.0	-6.7	-17.4			
26	Kartesisch	-	124.8	-1.1	40.7	16.4			
27	Kartesisch	-	124.8	-36.9	39.0	-19.4			
28	Kartesisch	-	119.0	-1.0	35.0	16.7			
29	Kartesisch	-	119.0	-37.0	33.3	-19.2			
30	Kartesisch	-	159.0	-1.0	74.9	14.9			
31	Kartesisch	-	159.0	-37.0	73.2	-21.1			
32	Kartesisch	-	82.1	-18.3	0.0	0.0			

## 1.2 MATERIALIEN

Material Nr.	Materialbezeichnung	Elastizitätsmodul E [N/mm <sup>2</sup> ]	Schubmodul G [N/mm <sup>2</sup> ]	Spez. Gewicht $\gamma$ [kN/m <sup>3</sup> ]	Teilsich.-Beiwert $\gamma_M$ [-]
1*	Aluminium EN-AW 6063 (DT) T66   EN 1999-1-1:2007 *) Referenzmaterial	70000.0	27000.0	27.00	1.00

## 1.2.1 MATERIALIEN - GRENZSPANNUNG

Material Nr.	Materialbezeichnung	Elementdicke [mm]		Streckgrenze $f_{y,k}$ [N/mm <sup>2</sup> ]	Grenzfestigkeit $f_{uk}$ [N/mm <sup>2</sup> ]	Grenzspannung [N/mm <sup>2</sup> ]		
		Von	Bis			$\sigma_x$	$\tau$	$\sigma_v$
1	Aluminium EN-AW 6063 (DT) T66   EN 1999-1-1:2007	0.0	20.0	195.0	230.0	195.0	112.6	195.0

## 1.3 QUERSCHNITTE

Quers. Nr.	Querschnittsbezeichnung	Material Nr.	Profilversatzpunkte		Lage		Drehung $\beta$ [°]	Fläche A [mm <sup>2</sup> ]
			y [mm]	z [mm]	Y [mm]	Z [mm]		
1	40G	1	0.0	0.0	-0.7	0.0	0.00	1179.8

## 1.4 ELEMENTE

Element Nr.	Typ	Knoten Nr.	Material Nr.	Dicke [mm]	Länge [mm]	Kommentar
1	Polylinie	1,15	1	2.0	0.7	
2	Polylinie	3,10	1	2.0	28.0	
3	Polylinie	5,2	1	2.0	39.0	
4	Polylinie	6,7	1	2.0	40.0	
5	Polylinie	7,8	1	2.0	40.0	
6	Polylinie	8,9	1	2.0	5.8	
7	Polylinie	9,17	1	2.0	34.2	
8	Polylinie	10,16	1	2.0	1.0	
9	Polylinie	11,12	1	2.0	40.0	
10	Polylinie	12,13	1	2.0	40.0	
11	Polylinie	13,14	1	2.0	5.8	
12	Polylinie	14,18	1	2.0	34.2	
13	Polylinie	15,6	1	2.0	39.0	
14	Polylinie	16,11	1	2.0	39.0	
15	Polylinie	17,5	1	2.0	1.0	
16	Polylinie	18,4	1	2.0	22.2	
17	Polylinie	20,21	1	2.0	36.0	
18	Polylinie	24,25	1	2.0	36.0	
19	Polylinie	30,31	1	2.0	36.0	
20	Polylinie	28,29	1	2.0	36.0	
21	Polylinie	16,19	1	0.0	1.0	
22	Polylinie	11,21	1	0.0	1.0	
23	Polylinie	15,22	1	0.0	1.0	
24	Polylinie	22,19	1	2.0	36.0	
25	Polylinie	6,20	1	0.0	1.0	
26	Polylinie	7,24	1	0.0	1.0	
27	Polylinie	12,25	1	0.0	1.0	
28	Polylinie	13,29	1	0.0	1.0	

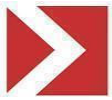

Projekt: 6168 AluTeck 40G

1.2

Projekt: Modell: AluTeck40G Datum: 21.05.2024

1.4 ELEMENTE

Table with 7 columns: Element Nr., Typ, Knoten Nr., Material Nr., Dicke [mm], Länge [mm], Kommentar. Rows 29-33 showing Polylinie elements.

4.1 QUERSCHNITTSWERTE

Large table with 6 columns: Bezeichnung, Symbol, Wert, Einheit, Kommentar. Lists various cross-section properties like Querschnittsfläche, Schubflächen, Trägheitsmomente, etc.



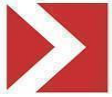

Projekt: 6168 AluTeck 40G

1.2

Projekt:

Modell: AluTeck40G

Datum:

21.05.2024

4.2 STATISCHE MOMENTE

Element Nr.	Knoten Nr.	Abstand s [mm]	Statische Momente [cm³]					
			S <sub>y</sub>	S <sub>z</sub>	S <sub>u</sub>	S <sub>v</sub>		
1	1	0.0	0.00	0.00	0.00	0.00		
	Mitte	0.3	0.01	-0.06	0.02	-0.06		
	15	0.7	0.03	-0.12	0.03	-0.12		
	15	0.7	0.03	-0.12	0.03	-0.12	max S <sub>y</sub>	
	1	0.0	0.00	0.00	0.00	0.00	min S <sub>y</sub>	
	1	0.0	0.00	0.00	0.00	0.00	max S <sub>z</sub>	
	15	0.7	0.03	-0.12	0.03	-0.12	min S <sub>z</sub>	
	15	0.7	0.03	-0.12	0.03	-0.12	max S <sub>u</sub>	
	1	0.0	0.00	0.00	0.00	0.00	min S <sub>u</sub>	
	1	0.0	0.00	0.00	0.00	0.00	max S <sub>v</sub>	
	15	0.7	0.03	-0.12	0.03	-0.12	min S <sub>v</sub>	
	2	3	0.0	0.00	0.00	0.00	0.00	
		Mitte	14.0	-0.52	-2.99	-0.38	-3.01	
		10	28.0	-1.05	-5.59	-0.78	-5.63	
		3	0.0	0.00	0.00	0.00	0.00	max S <sub>y</sub>
10		28.0	-1.05	-5.59	-0.78	-5.63	min S <sub>y</sub>	
3		0.0	0.00	0.00	0.00	0.00	max S <sub>z</sub>	
10		28.0	-1.05	-5.59	-0.78	-5.63	min S <sub>z</sub>	
3		0.0	0.00	0.00	0.00	0.00	max S <sub>u</sub>	
10		28.0	-1.05	-5.59	-0.78	-5.63	min S <sub>u</sub>	
3		0.0	0.00	0.00	0.00	0.00	max S <sub>v</sub>	
10		28.0	-1.05	-5.59	-0.78	-5.63	min S <sub>v</sub>	
3		5	0.0	-1.51	-7.38	-1.16	-7.45	
		Mitte	19.5	-0.75	-4.07	-0.56	-4.10	
		2	39.0	0.00	0.00	0.00	0.00	
		2	39.0	0.00	0.00	0.00	0.00	max S <sub>y</sub>
	5	0.0	-1.51	-7.38	-1.16	-7.45	min S <sub>y</sub>	
	2	39.0	0.00	0.00	0.00	0.00	max S <sub>z</sub>	
	5	0.0	-1.51	-7.38	-1.16	-7.45	min S <sub>z</sub>	
	2	39.0	0.00	0.00	0.00	0.00	max S <sub>u</sub>	
	5	0.0	-1.51	-7.38	-1.16	-7.45	min S <sub>u</sub>	
	2	39.0	0.00	0.00	0.00	0.00	max S <sub>v</sub>	
	5	0.0	-1.51	-7.38	-1.16	-7.45	min S <sub>v</sub>	
	4	6	0.0	-1.26	-12.58	-0.67	-12.63	
		Mitte	20.0	-0.49	-14.02	0.17	-14.02	
		7	40.0	0.28	-14.65	0.97	-14.62	
		7	40.0	0.28	-14.65	0.97	-14.62	max S <sub>y</sub>
6		0.0	-1.26	-12.58	-0.67	-12.63	min S <sub>y</sub>	
6		0.0	-1.26	-12.58	-0.67	-12.63	max S <sub>z</sub>	
7		40.0	0.28	-14.65	0.97	-14.62	min S <sub>z</sub>	
7		40.0	0.28	-14.65	0.97	-14.62	max S <sub>u</sub>	
6		0.0	-1.26	-12.58	-0.67	-12.63	min S <sub>u</sub>	
6		0.0	-1.26	-12.58	-0.67	-12.63	max S <sub>v</sub>	
7		40.0	0.28	-14.65	0.97	-14.62	min S <sub>v</sub>	
5		7	0.0	-1.23	-15.10	-0.52	-15.14	
		Mitte	20.0	-0.46	-14.93	0.24	-14.94	
		8	40.0	0.32	-13.97	0.97	-13.94	
		8	40.0	0.32	-13.97	0.97	-13.94	max S <sub>y</sub>
	7	0.0	-1.23	-15.10	-0.52	-15.14	min S <sub>y</sub>	
	8	40.0	0.32	-13.97	0.97	-13.94	max S <sub>z</sub>	
	8	40.0	0.32	-13.97	0.97	-13.94	min S <sub>z</sub>	
	8	40.0	0.32	-13.97	0.97	-13.94	max S <sub>u</sub>	
	7	0.0	-1.23	-15.10	-0.52	-15.14	min S <sub>u</sub>	
	8	40.0	0.32	-13.97	0.97	-13.94	max S <sub>v</sub>	
	6	8	4.9	-1.04	-15.13	-0.33	-15.16	
		Mitte	2.9	-1.16	-12.93	-0.55	-12.97	
		9	5.8	-1.05	-12.71	-0.45	-12.74	
		9	5.8	-1.05	-12.71	-0.45	-12.74	max S <sub>y</sub>
		8	0.0	-1.27	-13.14	-0.66	-13.18	min S <sub>y</sub>
9		5.8	-1.05	-12.71	-0.45	-12.74	max S <sub>z</sub>	
8		0.0	-1.27	-13.14	-0.66	-13.18	min S <sub>z</sub>	
9		5.8	-1.05	-12.71	-0.45	-12.74	max S <sub>u</sub>	
8		0.0	-1.27	-13.14	-0.66	-13.18	min S <sub>u</sub>	
9		5.8	-1.05	-12.71	-0.45	-12.74	max S <sub>v</sub>	
8		0.0	-1.27	-13.14	-0.66	-13.18	min S <sub>v</sub>	
7		9	0.0	-1.05	-12.71	-0.45	-12.74	
		Mitte	17.1	-0.39	-11.05	0.13	-11.05	
		17	34.2	0.28	-8.80	0.69	-8.78	
		17	34.2	0.28	-8.80	0.69	-8.78	max S <sub>y</sub>
	9	0.0	-1.05	-12.71	-0.45	-12.74	min S <sub>y</sub>	
	17	34.2	0.28	-8.80	0.69	-8.78	max S <sub>z</sub>	
	9	0.0	-1.05	-12.71	-0.45	-12.74	min S <sub>z</sub>	
	17	34.2	0.28	-8.80	0.69	-8.78	max S <sub>u</sub>	
	9	0.0	-1.05	-12.71	-0.45	-12.74	min S <sub>u</sub>	
	17	34.2	0.28	-8.80	0.69	-8.78	max S <sub>v</sub>	
	8	9	0.0	-1.05	-12.71	-0.45	-12.74	min S <sub>v</sub>
		10	0.0	-1.05	-5.59	-0.78	-5.63	
		Mitte	0.5	-1.06	-5.68	-0.80	-5.72	
		16	1.0	-1.08	-5.76	-0.81	-5.81	
		10	0.0	-1.05	-5.59	-0.78	-5.63	max S <sub>y</sub>
16		1.0	-1.08	-5.76	-0.81	-5.81	min S <sub>y</sub>	
10		0.0	-1.05	-5.59	-0.78	-5.63	max S <sub>z</sub>	
16		1.0	-1.08	-5.76	-0.81	-5.81	min S <sub>z</sub>	
10		0.0	-1.05	-5.59	-0.78	-5.63	max S <sub>u</sub>	
16		1.0	-1.08	-5.76	-0.81	-5.81	min S <sub>u</sub>	
10		0.0	-1.05	-5.59	-0.78	-5.63	max S <sub>v</sub>	
16		1.0	-1.08	-5.76	-0.81	-5.81	min S <sub>v</sub>	



Projekt: 6168 AluTeck 40G

1.2

Projekt:

Modell: AluTeck40G

Datum:

21.05.2024

4.2 STATISCHE MOMENTE

Table with columns: Element Nr., Knoten Nr., Abstand s [mm], Sy, Sz, Su, Sv. It lists static moments for various elements (9-16) at different nodes and distances, including maximum and minimum values for each axis.

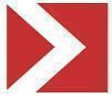

Projekt: 6168 AluTeck 40G

1.2

Projekt:

Modell: AluTeck40G

Datum:

21.05.2024

4.2 STATISCHE MOMENTE

Element Nr.	Knoten Nr.	Abstand s [mm]	Statische Momente [cm³]				
			S <sub>y</sub>	S <sub>z</sub>	S <sub>u</sub>	S <sub>v</sub>	
17	20	0.0	1.46	2.23	1.35	2.29	
	Mitte	18.0	1.79	0.58	1.77	0.66	
	21	36.0	1.48	-1.08	1.53	-1.00	
		18.3	1.79	0.54	1.77	0.63	max S <sub>y</sub>
	20	0.0	1.46	2.23	1.35	2.29	min S <sub>y</sub>
	20	0.0	1.46	2.23	1.35	2.29	max S <sub>z</sub>
	21	36.0	1.48	-1.08	1.53	-1.00	min S <sub>z</sub>
		20.5	1.79	0.35	1.77	0.43	max S <sub>u</sub>
	20	0.0	1.46	2.23	1.35	2.29	min S <sub>u</sub>
	20	0.0	1.46	2.23	1.35	2.29	max S <sub>v</sub>
	21	36.0	1.48	-1.08	1.53	-1.00	min S <sub>v</sub>
	18	24	0.0	1.51	0.45	1.49	0.52
Mitte		18.0	1.85	0.24	1.84	0.32	
25		36.0	1.54	0.03	1.54	0.10	
		18.3	1.85	0.23	1.84	0.32	max S <sub>y</sub>
24		0.0	1.51	0.45	1.49	0.52	min S <sub>y</sub>
24		0.0	1.51	0.45	1.49	0.52	max S <sub>z</sub>
25		36.0	1.54	0.03	1.54	0.10	min S <sub>z</sub>
		18.6	1.85	0.23	1.84	0.32	max S <sub>u</sub>
24		0.0	1.51	0.45	1.49	0.52	min S <sub>u</sub>
24		0.0	1.51	0.45	1.49	0.52	max S <sub>v</sub>
25		36.0	1.54	0.03	1.54	0.10	min S <sub>v</sub>
19		30	0.0	1.82	-1.27	1.88	-1.18
	Mitte	18.0	2.16	1.40	2.09	1.50	
	31	36.0	1.85	4.07	1.66	4.15	
		18.3	2.16	1.45	2.09	1.55	max S <sub>y</sub>
	30	0.0	1.82	-1.27	1.88	-1.18	min S <sub>y</sub>
	31	36.0	1.85	4.07	1.66	4.15	max S <sub>z</sub>
	30	0.0	1.82	-1.27	1.88	-1.18	min S <sub>z</sub>
		14.9	2.15	0.93	2.10	1.03	max S <sub>u</sub>
	31	36.0	1.85	4.07	1.66	4.15	min S <sub>u</sub>
	31	36.0	1.85	4.07	1.66	4.15	max S <sub>v</sub>
	30	0.0	1.82	-1.27	1.88	-1.18	min S <sub>v</sub>
	20	28	0.0	1.59	-0.83	1.62	-0.76
Mitte		18.0	1.92	0.40	1.90	0.49	
29		36.0	1.61	1.63	1.53	1.70	
		18.3	1.92	0.42	1.90	0.51	max S <sub>y</sub>
28		0.0	1.59	-0.83	1.62	-0.76	min S <sub>y</sub>
29		36.0	1.61	1.63	1.53	1.70	max S <sub>z</sub>
28		0.0	1.59	-0.83	1.62	-0.76	min S <sub>z</sub>
		16.7	1.92	0.31	1.90	0.40	max S <sub>u</sub>
29		36.0	1.61	1.63	1.53	1.70	min S <sub>u</sub>
29		36.0	1.61	1.63	1.53	1.70	max S <sub>v</sub>
28		0.0	1.59	-0.83	1.62	-0.76	min S <sub>v</sub>
21		16	0.0	-1.37	0.97	-1.41	0.90
	Mitte	0.5	-1.37	0.97	-1.41	0.90	
	19	1.0	-1.37	0.97	-1.41	0.90	
	16	0.0	-1.37	0.97	-1.41	0.90	max S <sub>y</sub>
	16	0.0	-1.37	0.97	-1.41	0.90	min S <sub>y</sub>
	16	0.0	-1.37	0.97	-1.41	0.90	max S <sub>z</sub>
	16	0.0	-1.37	0.97	-1.41	0.90	min S <sub>z</sub>
	16	0.0	-1.37	0.97	-1.41	0.90	max S <sub>u</sub>
	16	0.0	-1.37	0.97	-1.41	0.90	min S <sub>u</sub>
	16	0.0	-1.37	0.97	-1.41	0.90	max S <sub>v</sub>
	16	0.0	-1.37	0.97	-1.41	0.90	min S <sub>v</sub>
	22	11	0.0	-1.48	1.08	-1.53	1.00
Mitte		0.5	-1.48	1.08	-1.53	1.00	
21		1.0	-1.48	1.08	-1.53	1.00	
11		0.0	-1.48	1.08	-1.53	1.00	max S <sub>y</sub>
11		0.0	-1.48	1.08	-1.53	1.00	min S <sub>y</sub>
11		0.0	-1.48	1.08	-1.53	1.00	max S <sub>z</sub>
11		0.0	-1.48	1.08	-1.53	1.00	min S <sub>z</sub>
11		0.0	-1.48	1.08	-1.53	1.00	max S <sub>u</sub>
11		0.0	-1.48	1.08	-1.53	1.00	min S <sub>u</sub>
11		0.0	-1.48	1.08	-1.53	1.00	max S <sub>v</sub>
11		0.0	-1.48	1.08	-1.53	1.00	min S <sub>v</sub>
23		15	0.0	1.34	5.14	1.10	5.20
	Mitte	0.5	1.34	5.14	1.10	5.20	
	22	1.0	1.34	5.14	1.10	5.20	
	15	0.0	1.34	5.14	1.10	5.20	max S <sub>y</sub>
	15	0.0	1.34	5.14	1.10	5.20	min S <sub>y</sub>
	15	0.0	1.34	5.14	1.10	5.20	max S <sub>z</sub>
	15	0.0	1.34	5.14	1.10	5.20	min S <sub>z</sub>
	15	0.0	1.34	5.14	1.10	5.20	max S <sub>u</sub>
	15	0.0	1.34	5.14	1.10	5.20	min S <sub>u</sub>
	15	0.0	1.34	5.14	1.10	5.20	max S <sub>v</sub>
	15	0.0	1.34	5.14	1.10	5.20	min S <sub>v</sub>
	24	22	0.0	1.34	5.14	1.10	5.20
Mitte		18.0	1.68	2.09	1.58	2.16	
19		36.0	1.37	-0.97	1.41	-0.90	
		18.3	1.68	2.03	1.58	2.10	max S <sub>y</sub>
22		0.0	1.34	5.14	1.10	5.20	min S <sub>y</sub>
22		0.0	1.34	5.14	1.10	5.20	max S <sub>z</sub>
19		36.0	1.37	-0.97	1.41	-0.90	min S <sub>z</sub>
		22.3	1.66	1.35	1.60	1.43	max S <sub>u</sub>
22		0.0	1.34	5.14	1.10	5.20	min S <sub>u</sub>
22		0.0	1.34	5.14	1.10	5.20	max S <sub>v</sub>
19		36.0	1.37	-0.97	1.41	-0.90	min S <sub>v</sub>



Projekt: 6168 AluTeck 40G

1.2

Projekt:

Modell: AluTeck40G

Datum:

21.05.2024

4.2 STATISCHE MOMENTE

Element Nr.	Knoten Nr.	Abstand s [mm]	Statische Momente [cm³]					
			S <sub>y</sub>	S <sub>z</sub>	S <sub>u</sub>	S <sub>v</sub>		
25	6	0.0	1.46	2.23	1.35	2.29		
	Mitte	0.5	1.46	2.23	1.35	2.29		
	20	1.0	1.46	2.23	1.35	2.29		
	6	0.0	1.46	2.23	1.35	2.29	max S <sub>y</sub>	
	6	0.0	1.46	2.23	1.35	2.29	min S <sub>y</sub>	
	6	0.0	1.46	2.23	1.35	2.29	max S <sub>z</sub>	
	6	0.0	1.46	2.23	1.35	2.29	min S <sub>z</sub>	
	6	0.0	1.46	2.23	1.35	2.29	max S <sub>u</sub>	
	6	0.0	1.46	2.23	1.35	2.29	min S <sub>u</sub>	
	6	0.0	1.46	2.23	1.35	2.29	max S <sub>v</sub>	
	6	0.0	1.46	2.23	1.35	2.29	min S <sub>v</sub>	
	26	7	0.0	1.51	0.45	1.49	0.52	
Mitte		0.5	1.51	0.45	1.49	0.52		
24		1.0	1.51	0.45	1.49	0.52		
7		0.0	1.51	0.45	1.49	0.52	max S <sub>y</sub>	
7		0.0	1.51	0.45	1.49	0.52	min S <sub>y</sub>	
7		0.0	1.51	0.45	1.49	0.52	max S <sub>z</sub>	
7		0.0	1.51	0.45	1.49	0.52	min S <sub>z</sub>	
7		0.0	1.51	0.45	1.49	0.52	max S <sub>u</sub>	
7		0.0	1.51	0.45	1.49	0.52	min S <sub>u</sub>	
7		0.0	1.51	0.45	1.49	0.52	max S <sub>v</sub>	
7		0.0	1.51	0.45	1.49	0.52	min S <sub>v</sub>	
27		12	0.0	-1.54	-0.03	-1.54	-0.10	
	Mitte	0.5	-1.54	-0.03	-1.54	-0.10		
	12	0.0	-1.54	-0.03	-1.54	-0.10	max S <sub>y</sub>	
	12	0.0	-1.54	-0.03	-1.54	-0.10	min S <sub>y</sub>	
	12	0.0	-1.54	-0.03	-1.54	-0.10	max S <sub>z</sub>	
	12	0.0	-1.54	-0.03	-1.54	-0.10	min S <sub>z</sub>	
	12	0.0	-1.54	-0.03	-1.54	-0.10	max S <sub>u</sub>	
	12	0.0	-1.54	-0.03	-1.54	-0.10	min S <sub>u</sub>	
	12	0.0	-1.54	-0.03	-1.54	-0.10	max S <sub>v</sub>	
	12	0.0	-1.54	-0.03	-1.54	-0.10	min S <sub>v</sub>	
	28	13	0.0	-1.61	-1.63	-1.53	-1.70	
		Mitte	0.5	-1.61	-1.63	-1.53	-1.70	
29		1.0	-1.61	-1.63	-1.53	-1.70		
13		0.0	-1.61	-1.63	-1.53	-1.70	max S <sub>y</sub>	
13		0.0	-1.61	-1.63	-1.53	-1.70	min S <sub>y</sub>	
13		0.0	-1.61	-1.63	-1.53	-1.70	max S <sub>z</sub>	
13		0.0	-1.61	-1.63	-1.53	-1.70	min S <sub>z</sub>	
13		0.0	-1.61	-1.63	-1.53	-1.70	max S <sub>u</sub>	
13		0.0	-1.61	-1.63	-1.53	-1.70	min S <sub>u</sub>	
13		0.0	-1.61	-1.63	-1.53	-1.70	max S <sub>v</sub>	
13		0.0	-1.61	-1.63	-1.53	-1.70	min S <sub>v</sub>	
29		8	0.0	1.59	-0.83	1.62	-0.76	
	Mitte	0.5	1.59	-0.83	1.62	-0.76		
	28	1.0	1.59	-0.83	1.62	-0.76		
	8	0.0	1.59	-0.83	1.62	-0.76	max S <sub>y</sub>	
	8	0.0	1.59	-0.83	1.62	-0.76	min S <sub>y</sub>	
	8	0.0	1.59	-0.83	1.62	-0.76	max S <sub>z</sub>	
	8	0.0	1.59	-0.83	1.62	-0.76	min S <sub>z</sub>	
	8	0.0	1.59	-0.83	1.62	-0.76	max S <sub>u</sub>	
	8	0.0	1.59	-0.83	1.62	-0.76	min S <sub>u</sub>	
	8	0.0	1.59	-0.83	1.62	-0.76	max S <sub>v</sub>	
	8	0.0	1.59	-0.83	1.62	-0.76	min S <sub>v</sub>	
	30	14	0.0	0.00	0.00	0.00	0.00	
Mitte		0.5	0.00	0.00	0.00	0.00		
27		1.1	0.00	0.00	0.00	0.00		
14		0.0	0.00	0.00	0.00	0.00	max S <sub>y</sub>	
14		0.0	0.00	0.00	0.00	0.00	min S <sub>y</sub>	
14		0.0	0.00	0.00	0.00	0.00	max S <sub>z</sub>	
14		0.0	0.00	0.00	0.00	0.00	min S <sub>z</sub>	
14		0.0	0.00	0.00	0.00	0.00	max S <sub>u</sub>	
14		0.0	0.00	0.00	0.00	0.00	min S <sub>u</sub>	
14		0.0	0.00	0.00	0.00	0.00	max S <sub>v</sub>	
14		0.0	0.00	0.00	0.00	0.00	min S <sub>v</sub>	
31		9	0.0	0.00	0.00	0.00	0.00	
	Mitte	0.5	0.00	0.00	0.00	0.00		
	26	1.1	0.00	0.00	0.00	0.00		
	9	0.0	0.00	0.00	0.00	0.00	max S <sub>y</sub>	
	9	0.0	0.00	0.00	0.00	0.00	min S <sub>y</sub>	
	9	0.0	0.00	0.00	0.00	0.00	max S <sub>z</sub>	
	9	0.0	0.00	0.00	0.00	0.00	min S <sub>z</sub>	
	9	0.0	0.00	0.00	0.00	0.00	max S <sub>u</sub>	
	9	0.0	0.00	0.00	0.00	0.00	min S <sub>u</sub>	
	9	0.0	0.00	0.00	0.00	0.00	max S <sub>v</sub>	
	9	0.0	0.00	0.00	0.00	0.00	min S <sub>v</sub>	
	32	17	0.0	1.82	-1.27	1.88	-1.18	
Mitte		0.5	1.82	-1.27	1.88	-1.18		
30		1.0	1.82	-1.27	1.88	-1.18		
17		0.0	1.82	-1.27	1.88	-1.18	max S <sub>y</sub>	
17		0.0	1.82	-1.27	1.88	-1.18	min S <sub>y</sub>	
17		0.0	1.82	-1.27	1.88	-1.18	max S <sub>z</sub>	
17		0.0	1.82	-1.27	1.88	-1.18	min S <sub>z</sub>	
17		0.0	1.82	-1.27	1.88	-1.18	max S <sub>u</sub>	
17		0.0	1.82	-1.27	1.88	-1.18	min S <sub>u</sub>	
17		0.0	1.82	-1.27	1.88	-1.18	max S <sub>v</sub>	
17		0.0	1.82	-1.27	1.88	-1.18	min S <sub>v</sub>	

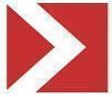

Projekt: 6168 AluTeck 40G

1.2

Projekt:

Modell: AluTeck40G

Datum:

21.05.2024

4.2 STATISCHE MOMENTE

Table with 9 columns: Element Nr., Knoten Nr., Abstand s [mm], Sy, Sz, Su, Sv, and values for static moments in cm³.

4.3 FLÄCHENMOMENTE (WÖLBFLÄCHEN)

Table with 6 columns: Element Nr., Knoten Nr., Abstand s [mm], Wölbeinsp. ωM [cm²], SωM [cm⁴], and values for area moments.



Projekt: 6168 AluTeck 40G

1.2

Projekt:

Modell: AluTeck40G

Datum:

21.05.2024

4.3 FLÄCHENMOMENTE (WÖLBFLÄCHEN)

Element Nr.	Knoten Nr.	Abstand s [mm]	Wölbeinsp.		
			$\omega_M$ [cm <sup>2</sup> ]	$S_{\omega M}$ [cm <sup>4</sup> ]	
9	11	0.0	-6.09	0.45	min $S_{\omega M}$
	10	0.0	-0.08	2.41	
	Mitte	20.0	2.93	1.84	
	13	40.0	5.94	0.06	
	13	40.0	5.94	0.06	
10	12	0.0	-0.08	2.41	max $\omega_M$
	12	0.5	0.00	2.41	min $\omega_M$
	13	40.0	5.94	0.06	max $S_{\omega M}$
	13	0.0	5.94	3.40	min $S_{\omega M}$
	Mitte	2.9	6.18	3.05	
11	14	5.8	6.42	2.69	
	14	5.8	6.42	2.69	max $\omega_M$
	13	0.0	5.94	3.40	min $\omega_M$
	13	0.0	5.94	3.40	max $S_{\omega M}$
	14	5.8	6.42	2.69	min $S_{\omega M}$
12	14	0.0	6.42	2.69	
	Mitte	17.1	7.83	0.25	
	18	34.2	9.24	-2.67	
	18	34.2	9.24	-2.67	max $\omega_M$
	14	0.0	6.42	2.69	min $\omega_M$
13	14	0.0	6.42	2.69	max $S_{\omega M}$
	18	34.2	9.24	-2.67	min $S_{\omega M}$
	15	0.0	11.37	4.28	
	Mitte	19.5	9.51	0.21	
	6	39.0	7.66	-3.14	
14	15	0.0	11.37	4.28	max $\omega_M$
	6	39.0	7.66	-3.14	min $\omega_M$
	15	0.0	11.37	4.28	max $S_{\omega M}$
	6	39.0	7.66	-3.14	min $S_{\omega M}$
	16	0.0	-9.26	-1.49	
15	Mitte	19.5	-7.67	1.81	
	11	39.0	-6.09	4.50	
	11	39.0	-6.09	4.50	max $\omega_M$
	16	0.0	-9.26	-1.49	min $\omega_M$
	11	39.0	-6.09	4.50	max $S_{\omega M}$
16	16	0.0	-9.26	-1.49	min $S_{\omega M}$
	17	0.0	-9.36	-4.56	
	Mitte	0.5	-9.27	-4.47	
	5	1.0	-9.18	-4.37	
	5	1.0	-9.18	-4.37	max $\omega_M$
17	17	0.0	-9.36	-4.56	min $\omega_M$
	5	1.0	-9.18	-4.37	max $S_{\omega M}$
	17	0.0	-9.36	-4.56	min $S_{\omega M}$
	18	0.0	9.24	3.13	
	Mitte	11.1	7.06	1.32	
18	4	22.2	4.87	0.00	
	18	0.0	9.24	3.13	max $\omega_M$
	4	22.2	4.87	0.00	min $\omega_M$
	18	0.0	9.24	3.13	max $S_{\omega M}$
	4	22.2	4.87	0.00	min $S_{\omega M}$
19	20	0.0	7.29	-3.49	
	Mitte	18.0	0.78	-4.94	
	21	36.0	-5.73	-4.05	
	20	0.0	7.29	-3.49	max $\omega_M$
	21	36.0	-5.73	-4.05	min $\omega_M$
20	20	0.0	7.29	-3.49	max $S_{\omega M}$
	20	0.0	7.29	-3.49	min $S_{\omega M}$
	20.2	0.00	-4.96		
	24	0.0	1.05	-0.14	
	Mitte	18.0	0.50	-0.42	
21	25	36.0	-0.05	-0.50	
	24	0.0	1.05	-0.14	max $\omega_M$
	25	36.0	-0.05	-0.50	min $\omega_M$
	24	0.0	1.05	-0.14	max $S_{\omega M}$
	24	0.0	1.05	-0.14	min $S_{\omega M}$
22	34.4	0.00	-0.50		
	30	0.0	-8.87	5.76	
	Mitte	18.0	-0.06	7.37	
	31	36.0	8.75	5.80	
	31	36.0	8.75	5.80	max $\omega_M$
23	30	0.0	-8.87	5.76	min $\omega_M$
	18.1	0.00	7.37		max $S_{\omega M}$
	30	0.0	-8.87	5.76	min $S_{\omega M}$
	28	0.0	-5.20	3.50	
	Mitte	18.0	0.22	4.40	
24	29	36.0	5.64	3.34	
	29	36.0	5.64	3.34	max $\omega_M$
	28	0.0	-5.20	3.50	min $\omega_M$
	28	0.0	-5.20	3.50	min $S_{\omega M}$
	17.3	0.00	4.40		max $S_{\omega M}$
25	29	36.0	5.64	3.34	min $S_{\omega M}$
	16	0.0	-9.26	5.20	
	Mitte	0.5	-8.98	5.20	
	19	1.0	-8.71	5.20	
	19	1.0	-8.71	5.20	max $\omega_M$
26	16	0.0	-9.26	5.20	min $\omega_M$
	16	0.0	-9.26	5.20	max $S_{\omega M}$
	16	0.0	-9.26	5.20	min $S_{\omega M}$
	11	0.0	-6.09	4.05	
	Mitte	0.5	-5.91	4.05	
27	21	1.0	-5.73	4.05	
	21	1.0	-5.73	4.05	max $\omega_M$



Projekt: 6168 AluTeck 40G

1.2

Projekt:

Modell: AluTeck40G

Datum:

21.05.2024

4.3 FLÄCHENMOMENTE (WÖLBFLÄCHEN)

Element Nr.	Knoten Nr.	Abstand s [mm]	Wölbeinsp.		
			$\omega_M$ [cm <sup>2</sup> ]	$S_{\omega M}$ [cm <sup>4</sup> ]	
22	11	0.0	-6.09	4.05	min $\omega_M$
	11	0.0	-6.09	4.05	max $S_{\omega M}$
	11	0.0	-6.09	4.05	min $S_{\omega M}$
23	15	0.0	11.37	-4.44	
	Mitte	0.5	11.10	-4.44	
	22	1.0	10.83	-4.44	
	15	0.0	11.37	-4.44	max $\omega_M$
	22	1.0	10.83	-4.44	min $\omega_M$
	15	0.0	11.37	-4.44	max $S_{\omega M}$
24	15	0.0	11.37	-4.44	min $S_{\omega M}$
	22	0.0	10.83	-4.44	
	Mitte	18.0	1.06	-6.58	
	19	36.0	-8.71	-5.20	
	22	0.0	10.83	-4.44	max $\omega_M$
	19	36.0	-8.71	-5.20	min $\omega_M$
25	22	0.0	10.83	-4.44	max $S_{\omega M}$
	22	0.0	10.83	-4.44	min $S_{\omega M}$
		19.9	0.00	-6.60	
	6	0.0	7.66	-3.49	
	Mitte	0.5	7.48	-3.49	
	20	1.0	7.29	-3.49	
26	6	0.0	7.66	-3.49	max $\omega_M$
	20	1.0	7.29	-3.49	min $\omega_M$
	6	0.0	7.66	-3.49	max $S_{\omega M}$
	6	0.0	7.66	-3.49	min $S_{\omega M}$
	7	0.0	1.08	-0.14	
	Mitte	0.5	1.07	-0.14	
27	24	1.0	1.05	-0.14	
	7	0.0	1.08	-0.14	max $\omega_M$
	24	1.0	1.05	-0.14	min $\omega_M$
	7	0.0	1.08	-0.14	max $S_{\omega M}$
	7	0.0	1.08	-0.14	min $S_{\omega M}$
	12	0.0	-0.08	0.50	
28	Mitte	0.5	-0.06	0.50	
	25	1.0	-0.05	0.50	
	25	1.0	-0.05	0.50	max $\omega_M$
	12	0.0	-0.08	0.50	min $\omega_M$
	12	0.0	-0.08	0.50	max $S_{\omega M}$
	12	0.0	-0.08	0.50	min $S_{\omega M}$
29	13	0.0	5.94	-3.34	
	Mitte	0.5	5.79	-3.34	
	29	1.0	5.64	-3.34	
	13	0.0	5.94	-3.34	max $\omega_M$
	29	1.0	5.64	-3.34	min $\omega_M$
	13	0.0	5.94	-3.34	max $S_{\omega M}$
30	13	0.0	5.94	-3.34	min $S_{\omega M}$
	8	0.0	-5.50	3.50	
	Mitte	0.5	-5.35	3.50	
	28	1.0	-5.20	3.50	
	28	1.0	-5.20	3.50	max $\omega_M$
	8	0.0	-5.50	3.50	min $\omega_M$
31	8	0.0	-5.50	3.50	max $S_{\omega M}$
	8	0.0	-5.50	3.50	min $S_{\omega M}$
	14	0.0	6.42	0.00	
	Mitte	0.5	6.18	0.00	
	27	1.1	5.95	0.00	
	14	0.0	6.42	0.00	max $\omega_M$
32	27	1.1	5.95	0.00	min $\omega_M$
	14	0.0	6.42	0.00	max $S_{\omega M}$
	14	0.0	6.42	0.00	min $S_{\omega M}$
	9	0.0	-6.05	0.00	
	Mitte	0.5	-5.82	0.00	
	26	1.1	-5.59	0.00	
33	26	1.1	-5.59	0.00	max $\omega_M$
	9	0.0	-6.05	0.00	min $\omega_M$
	9	0.0	-6.05	0.00	max $S_{\omega M}$
	9	0.0	-6.05	0.00	min $S_{\omega M}$
	17	0.0	-9.36	5.76	
	Mitte	0.5	-9.12	5.76	
34	30	1.0	-8.87	5.76	
	30	1.0	-8.87	5.76	max $\omega_M$
	17	0.0	-9.36	5.76	min $\omega_M$
	17	0.0	-9.36	5.76	max $S_{\omega M}$
	17	0.0	-9.36	5.76	min $S_{\omega M}$
	18	0.0	9.24	-5.80	
35	Mitte	0.5	9.00	-5.80	
	31	1.0	8.75	-5.80	
	18	0.0	9.24	-5.80	max $\omega_M$
	31	1.0	8.75	-5.80	min $\omega_M$
	18	0.0	9.24	-5.80	max $S_{\omega M}$
	18	0.0	9.24	-5.80	min $S_{\omega M}$
Max/Min in gesamtem Querschnitt					
1	15	0.7	11.37	-0.16	MAX $\omega_M$
7	17	34.2	-9.36	1.20	MIN $\omega_M$
19		18.1	0.00	7.37	MAX $S_{\omega M}$
24		19.9	0.00	-6.60	MIN $S_{\omega M}$



**2.0 Einfeldträger**





## 2.1 Einfeldträger l = 2,15m

### System:

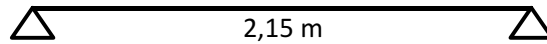

### Belastung:

Eigengew. Profile: aus EDV- Berechnung

Nutzlast: Die Nutzlast wird auf 5 Dielen je Meter verlegte Elemente verteilt

$$p = 4,0 / 5 = 0,8 \text{ kN/m}$$

Gebrauchstauglichkeit: Begrenzung Verformung  $\leq l / 200$

$$u = 1,01 \text{ cm} = l / 213$$

Tragfähigkeit:  $M_{Ed} = 0,72 \text{ kNm}$

$$W = 16,47 \text{ cm}^3$$

$$\sigma = 0,72 \times 100 / 16,47 = 4,4 \text{ kN/cm}^2 < 24,5 / 1,25 = 19,6 \text{ kN/cm}^2$$

Die Spannweite ist als Grenzspannweite festgelegt. Kürzere Spannweiten sind möglich.



Projekt: 6168 AluTeck 40G

2.1

Projekt: Modell: 2.1 Einfeld l = 2,15 m Datum: 21.05.2024

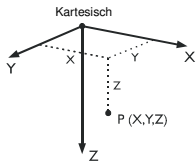

1.1 KNOTEN

Knoten Nr.	Bezugs-Knoten	Koordinaten-System	Knotenkoordinaten			Kommentar
			X [m]	Y [m]	Z [m]	
1	-	Kartesisch	0.000	0.000	0.000	Abgestützt
2	-	Kartesisch	2.150	0.000	0.000	Abgestützt

MODELL

LF1 : ständige Last

Isometrie

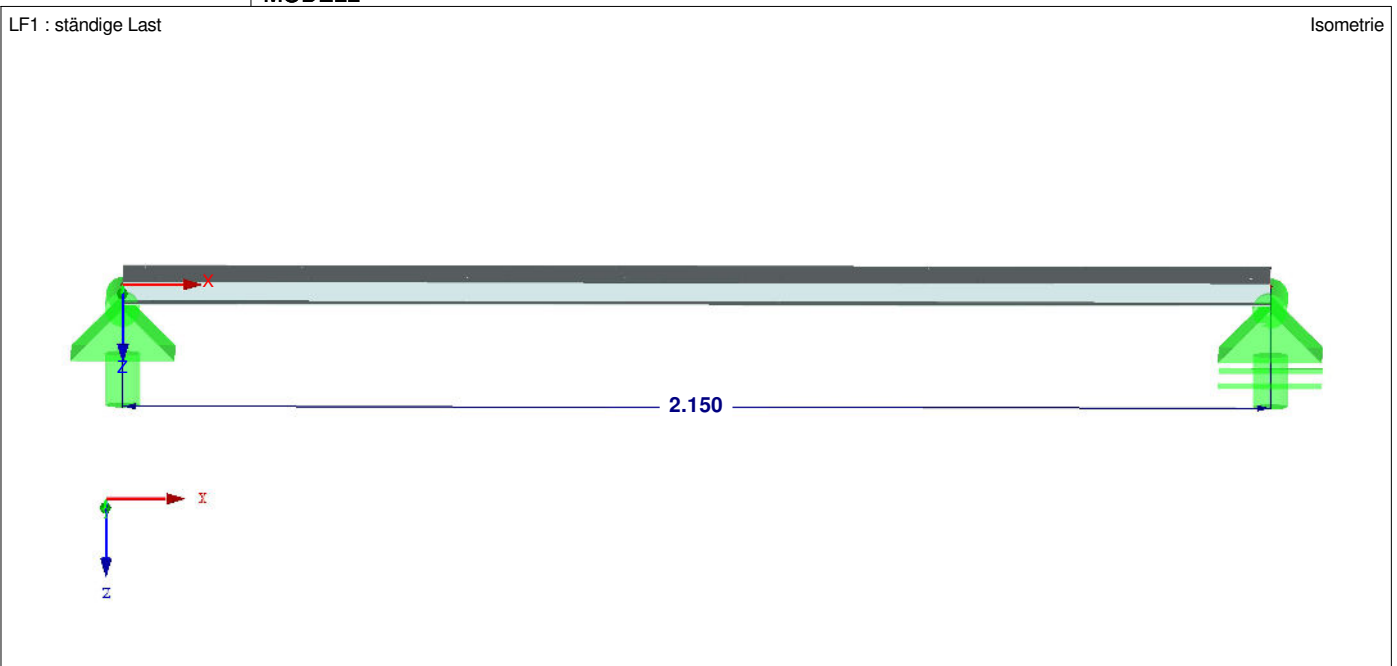

1.2 MATERIALIEN

Mat. Nr.	Modul E [kN/cm <sup>2</sup> ]	Modul G [kN/cm <sup>2</sup> ]	Spez. Gewicht $\gamma$ [kN/m <sup>3</sup> ]	Wärmedehnz. $\alpha$ [1/K]	Teilsich.-Beiwert $\gamma_M$ [-]	Material-Modell
1	Aluminium EN-AW 6063 (DT) T66   EN 1999-1-1:2007 7000.00	2700.00	27.00	2.30E-05	1.00	Isotrop linear elastisch

1.3 QUERSCHNITTE



Quers. Nr.	Mater. Nr.	I <sub>T</sub> [cm <sup>4</sup> ]	I <sub>y</sub> [cm <sup>4</sup> ]	I <sub>v</sub> [cm <sup>4</sup> ]	Hauptachsen $\alpha$ [°]	Drehung $\alpha'$ [°]	Gesamtabmessungen [mm]	
							A [cm <sup>2</sup> ]	A <sub>u</sub> [cm <sup>2</sup> ]
1	DUENQ ALUTECK40G 1	75.89 11.80	32.66 6.78	414.96 3.17	2.68	0.00	228.0	40.0

1.7 STÄBE

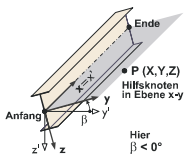

Stab Nr.	Stabtyp	Knoten		Drehung Typ	Drehung $\beta$ [°]	Querschnitt		Gelenk Nr.		Exz. Nr.	Teilung Nr.	Länge L [m]	
		Anfang	Ende			Anfang	Ende	Anfang	Ende				
1	Balkenstab	1	2	Winkel	0.00	1	1	-	-	-	-	2.150	X

1.8 KNOTENLAGER

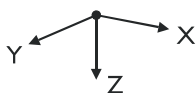

Lager Nr.	Knoten Nr.	Folge	Lagerdrehung [°]			Stütze in Z	Lagerung bzw. Feder					
			um X	um Y	um Z		u <sub>x</sub>	u <sub>y</sub>	u <sub>z</sub>	$\phi_x$	$\phi_y$	$\phi_z$
1	1	XYZ	0.00	0.00	0.00	<input type="checkbox"/>	<input checked="" type="checkbox"/>	<input checked="" type="checkbox"/>	<input checked="" type="checkbox"/>	<input checked="" type="checkbox"/>	<input type="checkbox"/>	<input type="checkbox"/>
2	2	XYZ	0.00	0.00	0.00	<input type="checkbox"/>	<input type="checkbox"/>	<input checked="" type="checkbox"/>	<input checked="" type="checkbox"/>	<input checked="" type="checkbox"/>	<input type="checkbox"/>	<input type="checkbox"/>

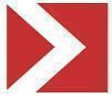

Projekt: 6168 AluTeck 40G

2.1

Projekt: Modell: 2.1 Einfeld l = 2,15 m Datum: 21.05.2024

2.1 LASTFÄLLE

Lastfall	LF-Bezeichnung	Keine Norm Einwirkungskategorie	Eigengewicht - Faktor in Richtung			
			Aktiv	X	Y	Z
LF1	ständige Last	Ständige Lasten	<input checked="" type="checkbox"/>	0.000	0.000	1.000
LF2	Nutzlast	Nutzlasten	<input type="checkbox"/>			

2.5 LASTKOMBINATIONEN

Lastkombin.	BS	Lastkombination Bezeichnung	Nr.	Faktor	Lastfall	
					1	2
LK1		1.35*LF1 + 1.5*LF2	1	1.35	LF1	ständige Last
			2	1.50	LF2	Nutzlast
LK2		LF1 + LF2	1	1.00	LF1	ständige Last
			2	1.00	LF2	Nutzlast

LAGERREAKTIONEN, LF1

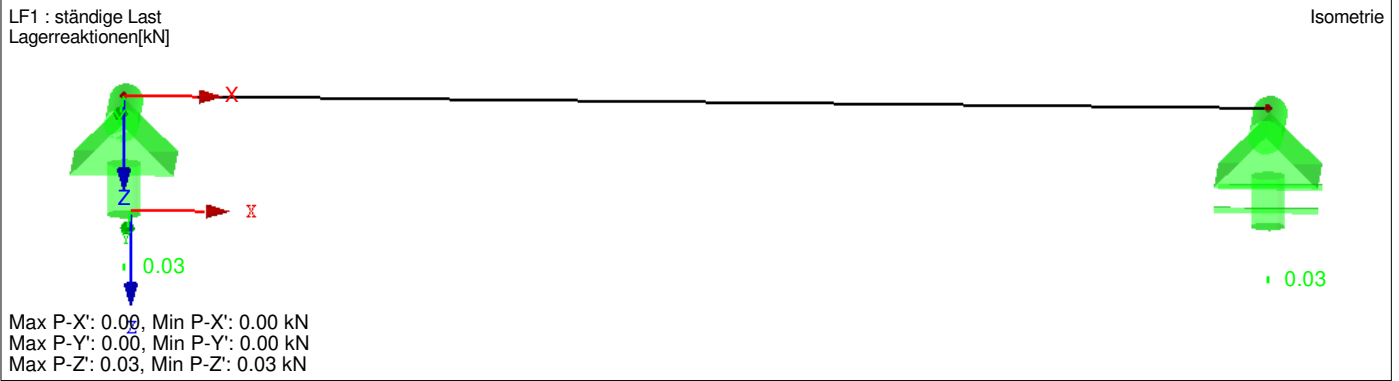

3.2 STABLASTEN

LF2  
Nutzlast

Nr.	Beziehen auf	An Stäben Nr.	Last-Art	Last-Verteilung	Last-Richtung	Bezugs-Länge	Lastparameter		
							Symbol	Wert	Einheit
1	Stäbe	1	Kraft	Konstant	Z	Wahre Länge	p	0.800	kN/m

LF2: Nutzlast

LAGERREAKTIONEN, LF2

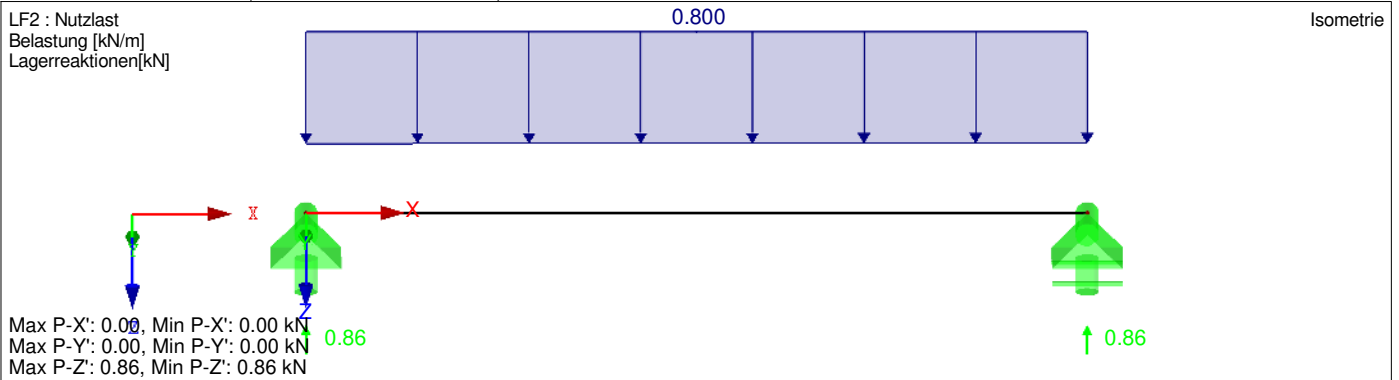

4.3 QUERSCHNITTE - SCHNITTGRÖSSEN

Stab Nr.	LF/LK	Knoten Nr.	Stelle x [m]	Kräfte [kN]			Momente [kNm]		
				N	V <sub>u</sub>	V <sub>v</sub>	M <sub>T</sub>	M <sub>u</sub>	M <sub>v</sub>
Querschnitt-Nr. 1: DUENQ ALUTECK40G									
1	LF1	MAX N	0.000	0.00	0.00	0.03	0.00	0.00	0.00
1	LF1	MIN N	0.000	0.00	0.00	0.03	0.00	0.00	0.00
1	LK1	MAX V <sub>y</sub>	0.000	0.00	0.10	-1.33	0.00	0.00	0.00
1	LK1	MIN V <sub>y</sub>	2.150	0.00	-0.10	-1.33	0.00	0.00	0.00
1	LK1	MAX V <sub>z</sub>	0.000	0.00	0.10	1.33	0.00	0.00	0.00
1	LK1	MIN V <sub>z</sub>	2.150	0.00	-0.10	-1.33	0.00	0.00	0.00
1	LF1	MAX M <sub>T</sub>	0.000	0.00	0.00	0.03	0.00	0.00	0.00
1	LF1	MIN M <sub>T</sub>	0.000	0.00	0.00	0.03	0.00	0.00	0.00
1	LK1	MAX M <sub>y</sub>	1.075	0.00	0.00	0.00	0.00	0.72	-0.05
1	LK1	MIN M <sub>y</sub>	0.000	0.00	0.10	1.33	0.00	0.00	0.00
1	LF1	MAX M <sub>z</sub>	0.000	0.00	0.00	0.03	0.00	0.00	0.00
1	LK1	MIN M <sub>z</sub>	1.075	0.00	0.00	0.00	0.00	0.72	-0.05



Projekt: 6168 AluTeck 40G

2.1

Projekt:

Modell: 2.1 Einfeld l = 2,15 m

Datum:

21.05.2024

■ SCHNITTGRÖSSEN  $M_y$ , LK1: 1.35\*LF1 + 1.5\*LF2

LK1 : 1.35\*LF1 + 1.5\*LF2  
Schnittgrößen M-u

Isometrie

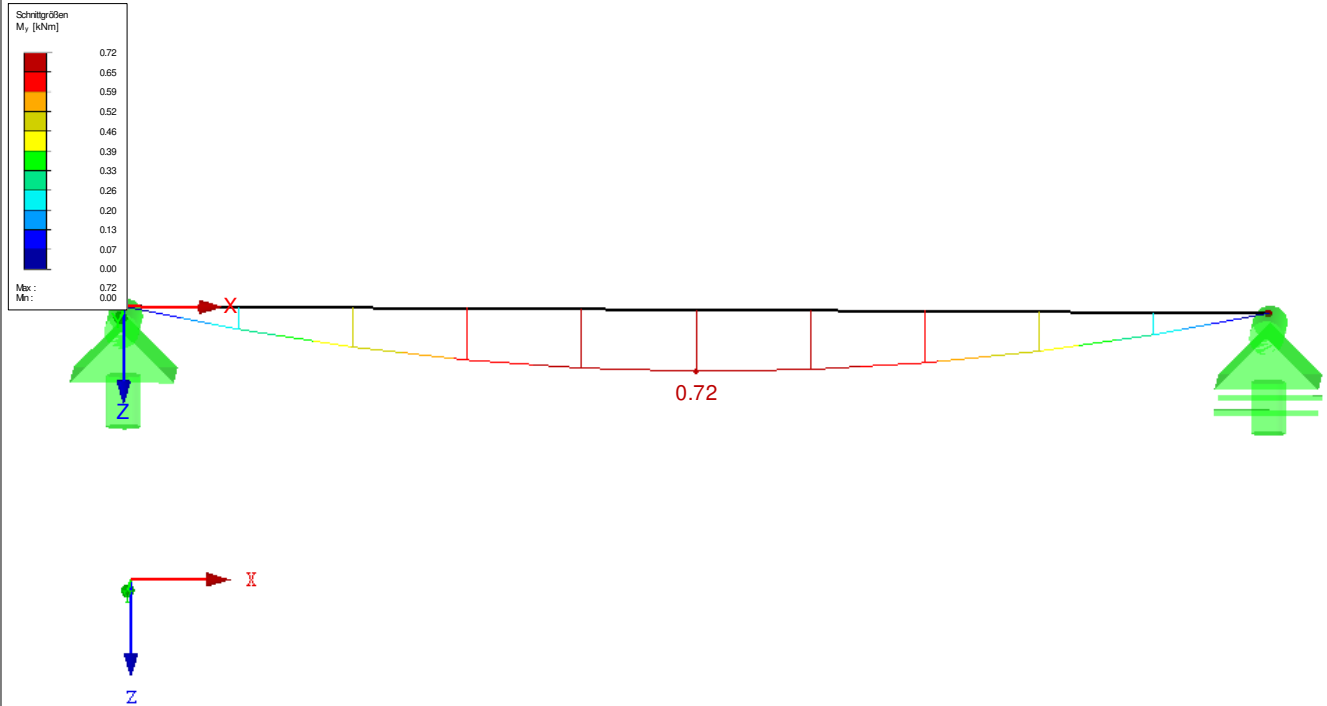

Max M-u: 0.72, Min M-u: 0.00 [kNm]

■ GLOBALE VERFORMUNGEN u

LK2 : LF1 + LF2  
Globale Verformungen u [mm]

Isometrie

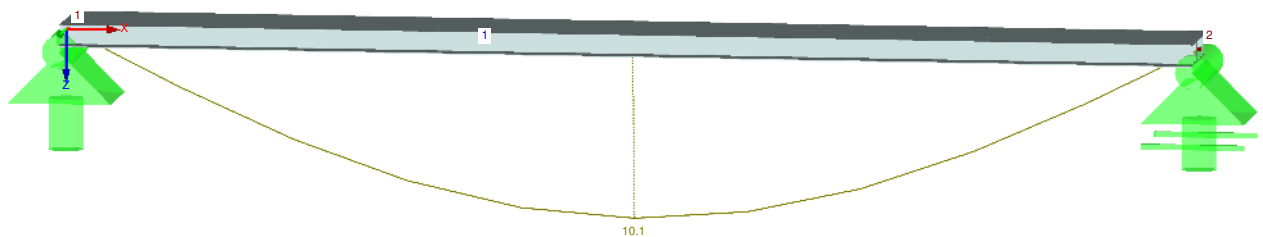

Max u: 10.1, Min u: 0.0 [mm]  
Faktor für Verformungen: 34.00



## 2.2 Einfeldträger I = 2,15m mit Kragarm

### System:

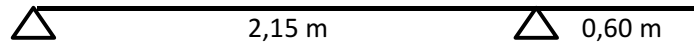

### Belastung:

Eigengew. Profile: aus EDV- Berechnung

Nutzlast: Die Nutzlast wird auf 5 Dielen je Meter verlegte Elemente verteilt

$$p = 4,0 / 5 = 0,8 \text{ kN/m}$$

Gebrauchstauglichkeit: Begrenzung Verformung  $\leq l / 200$  im Feld

$$u = 1,00 \text{ cm} = l / 215$$

Begrenzung Verformung  $\leq l / 150$  am Kragarm

$$u = 0,31 \text{ cm} = l / 194$$

Tragfähigkeit:  $M_{Ed} = 0,71 \text{ kNm}$

$$W = 16,47 \text{ cm}^3$$

$$\sigma = 0,71 \times 100 / 16,47 = 4,3 \text{ kN/cm}^2 < 24,5 / 1,25 = 19,6 \text{ kN/cm}^2$$

Die Spannweite ist als Grenzspannweite festgelegt. Kürzere Spannweiten sind möglich.



Projekt: 6168 AluTeck 40G

2.2

Projekt: Modell: 2.2 Einfeld mit Kragarm Datum: 21.05.2024

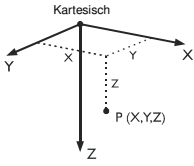

1.1 KNOTEN

Knoten Nr.	Bezugs-Knoten	Koordinaten-System	Knotenkoordinaten			Kommentar
			X [m]	Y [m]	Z [m]	
1	-	Kartesisch	0.000	0.000	0.000	Abgestützt
2	-	Kartesisch	2.150	0.000	0.000	Abgestützt
3	-	Kartesisch	2.750	0.000	0.000	

MODELL

LF1 : ständige Last

Isometrie

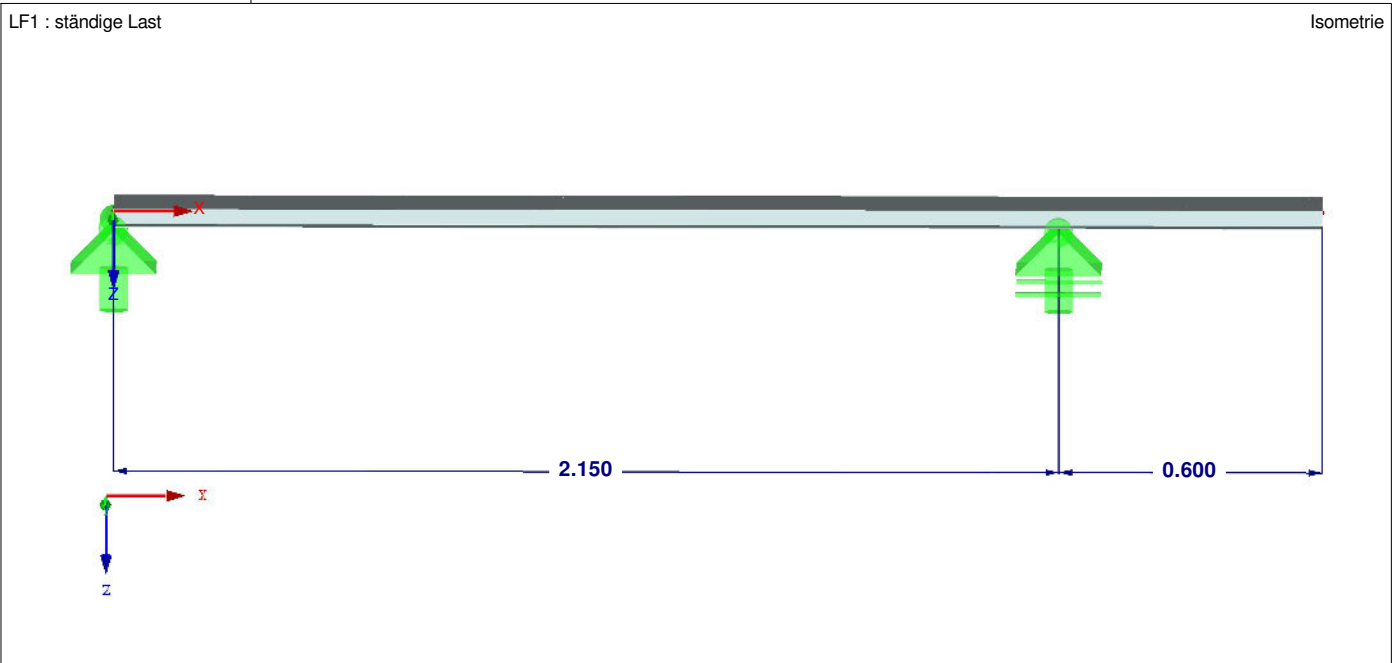

1.2 MATERIALIEN

Mat. Nr.	Modul E [kN/cm <sup>2</sup> ]	Modul G [kN/cm <sup>2</sup> ]	Spez. Gewicht $\gamma$ [kN/m <sup>3</sup> ]	Wärmedehn. $\alpha$ [1/K]	Teilsich.-Beiwert $\gamma_M$ [-]	Material-Modell
1	Aluminium EN-AW 6063 (DT) T66   EN 1999-1-1:2007 7000.00	2700.00	27.00	2.30E-05	1.00	Isotrop linear elastisch

1.3 QUERSCHNITTE



Quers. Nr.	Mater. Nr.	I <sub>T</sub> [cm <sup>4</sup> ]	I <sub>y</sub> [cm <sup>4</sup> ]	I <sub>x</sub> [cm <sup>4</sup> ]	Hauptachsen $\alpha$ [°]	Drehung $\alpha'$ [°]	Gesamtabmessungen [mm]	
							Breite b	Höhe h
1	DUENQ ALUTECK40G 1	75.89 11.80	32.66 6.78	414.96 3.17	2.68	0.00	228.0	40.0

1.7 STÄBE

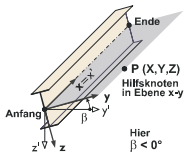

Stab Nr.	Stabtyp	Knoten		Drehung Typ	$\beta$ [°]	Querschnitt		Gelenk Nr.		Exz. Nr.	Teilung Nr.	Länge L [m]	
		Anfang	Ende			Anfang	Ende	Anfang	Ende				
1	Balkenstab	1	2	Winkel	0.00	1	1	-	-	-	-	2.150	X
2	Balkenstab	2	3	Winkel	0.00	1	1	-	-	-	-	0.600	X

1.8 KNOTENLAGER

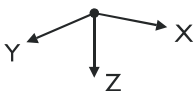

Lager Nr.	Knoten Nr.	Folge	Lagerdrehung [°]			Stütze in Z	Lagerung bzw. Feder					
			um X	um Y	um Z		u <sub>x</sub>	u <sub>y</sub>	u <sub>z</sub>	$\phi_x$	$\phi_y$	$\phi_z$
1	1	XYZ	0.00	0.00	0.00	<input type="checkbox"/>	<input checked="" type="checkbox"/>	<input checked="" type="checkbox"/>	<input checked="" type="checkbox"/>	<input checked="" type="checkbox"/>	<input type="checkbox"/>	<input type="checkbox"/>
2	2	XYZ	0.00	0.00	0.00	<input type="checkbox"/>	<input type="checkbox"/>	<input checked="" type="checkbox"/>	<input checked="" type="checkbox"/>	<input checked="" type="checkbox"/>	<input type="checkbox"/>	<input type="checkbox"/>



Projekt: 6168 AluTeck 40G

2.2

Projekt: Modell: 2.2 Einfeld mit Kragarm Datum: 21.05.2024

2.1 LASTFÄLLE

Lastfall	LF-Bezeichnung	Keine Norm Einwirkungskategorie	Eigengewicht - Faktor in Richtung			
			Aktiv	X	Y	Z
LF1	ständige Last	Ständige Lasten	<input checked="" type="checkbox"/>	0.000	0.000	1.000
LF2	Nutzlast Vollast	Nutzlasten	<input type="checkbox"/>			
LF3	Nutzlast Feld	Nutzlasten	<input type="checkbox"/>			
LF4	Nutzlast Kragarm	Nutzlasten	<input type="checkbox"/>			

2.5 LASTKOMBINATIONEN

Lastkombin.	BS	Lastkombination Bezeichnung	Nr.	Faktor	Lastfall	
LK1		1.35*LF1 + 1.5*LF2	1	1.35	LF1	ständige Last
			2	1.50	LF2	Nutzlast Vollast
LK2		1.35*LF1 + 1.5*LF3	1	1.35	LF1	ständige Last
			2	1.50	LF3	Nutzlast Feld
LK3		1.35*LF1 + 1.5*LF4	1	1.35	LF1	ständige Last
			2	1.50	LF4	Nutzlast Kragarm
LK4		LF1 + LF2	1	1.00	LF1	ständige Last
			2	1.00	LF2	Nutzlast Vollast
LK5		LF1 + LF3	1	1.00	LF1	ständige Last
			2	1.00	LF3	Nutzlast Feld
LK6		LF1 + LF4	1	1.00	LF1	ständige Last
			2	1.00	LF4	Nutzlast Kragarm

LAGERREAKTIONEN, LF1

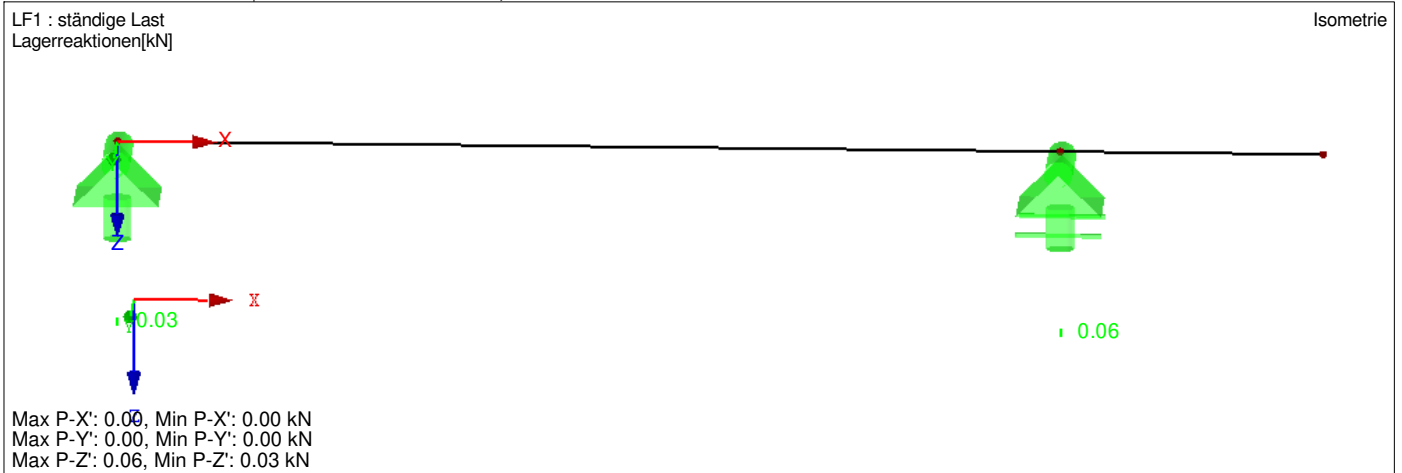

3.2 STABLASTEN

LF2  
Nutzlast Vollast

Nr.	Beziehen auf	An Stäben Nr.	Last-Art	Last-Verteilung	Last-Richtung	Bezugs-Länge	Lastparameter		
							Symbol	Wert	Einheit
1	Stäbe	1,2	Kraft	Konstant	Z	Wahre Länge	p	0.800	kN/m

LAGERREAKTIONEN, LF2

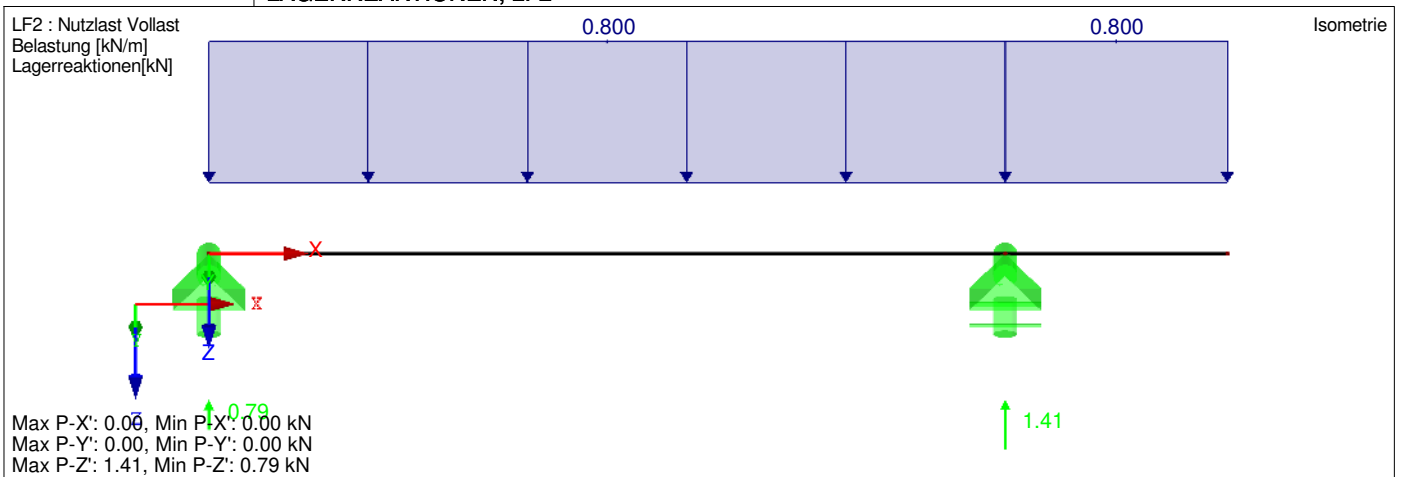



Projekt: 6168 AluTeck 40G

2.2

Projekt: Modell: 2.2 Einfeld mit Kragarm Datum: 21.05.2024

LF3  
Nutzlast Feld

3.2 STABLASTEN

LF3: Nutzlast Feld

Nr.	Beziehen auf	An Stäben Nr.	Last-Art	Last-verteilung	Last-Richtung	Bezugs-Länge	Symbol	Lastparameter Wert	Einheit
1	Stäbe	1	Kraft	Konstant	Z	Wahre Länge	p	0.800	kN/m

LAGERREAKTIONEN

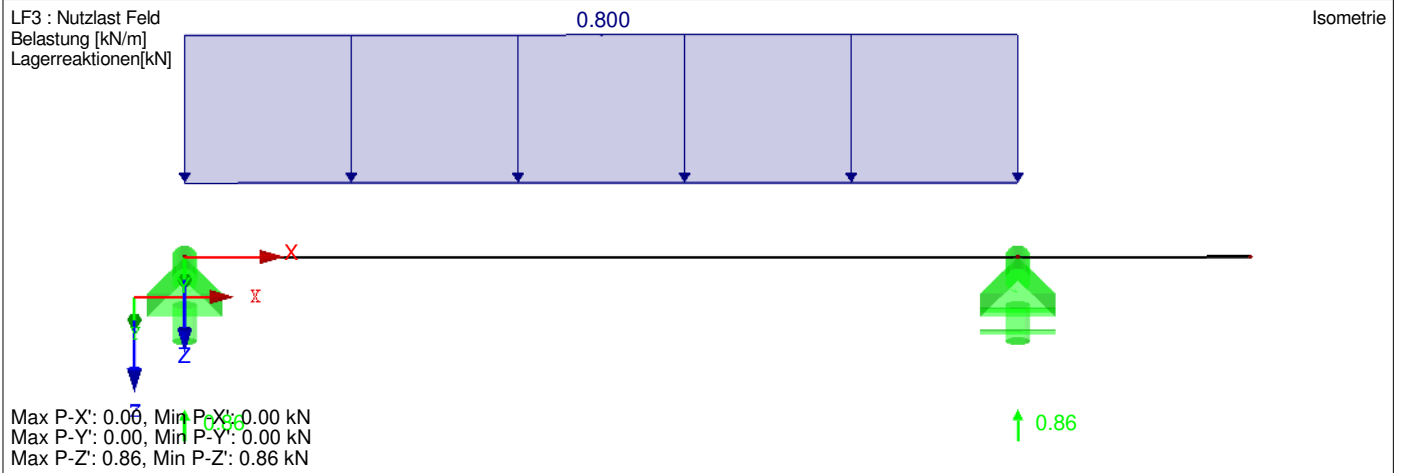

LAGERREAKTIONEN

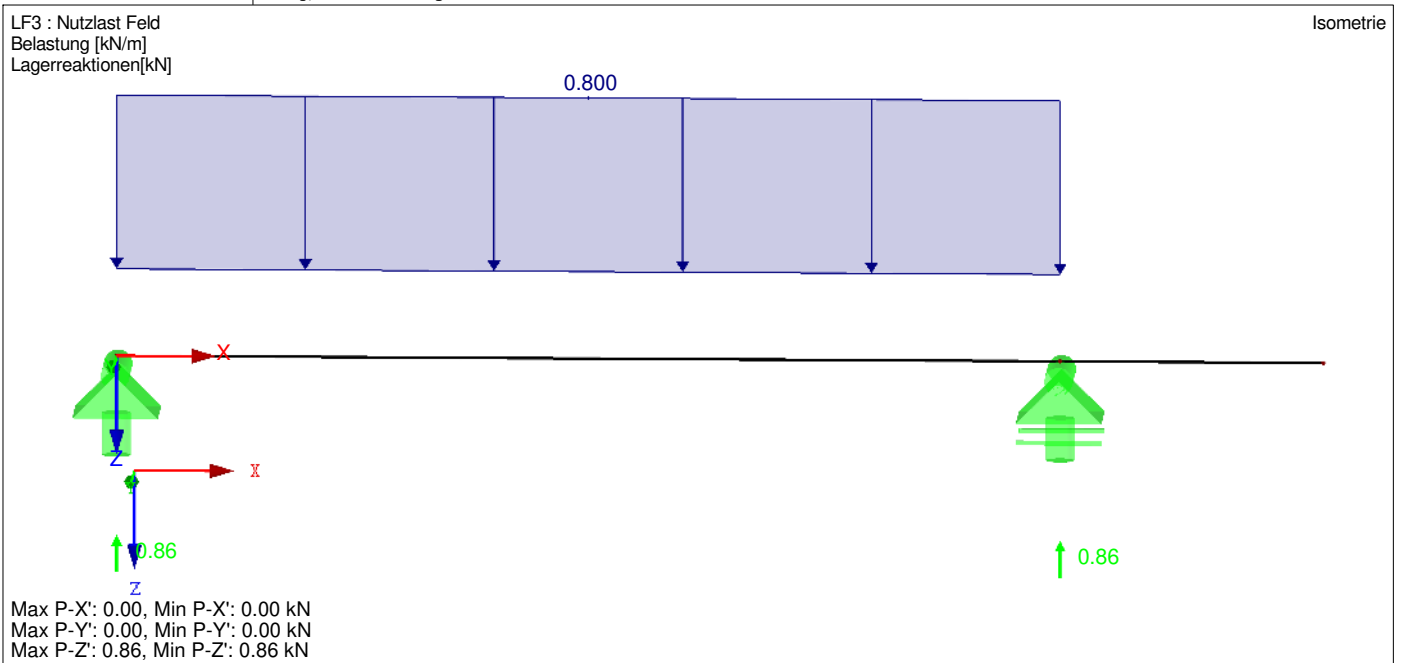

LF4  
Nutzlast Kragarm

3.2 STABLASTEN

LF4: Nutzlast Kragarm

Nr.	Beziehen auf	An Stäben Nr.	Last-Art	Last-verteilung	Last-Richtung	Bezugs-Länge	Symbol	Lastparameter Wert	Einheit
1	Stäbe	2	Kraft	Konstant	Z	Wahre Länge	p	0.800	kN/m



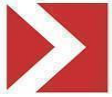

Projekt: 6168 AluTeck 40G

2.2

Projekt:

Modell: 2.2 Einfeld mit Kragarm

Datum:

21.05.2024

LAGERREAKTIONEN, LF4



LAGERREAKTIONEN



4.3 QUERSCHNITTE - SCHNITTGRÖSSEN

Stab Nr.	LF/LK	Knoten Nr.	Stelle x [m]	Kräfte [kN]			Momente [kNm]		
				N	V <sub>u</sub>	V <sub>v</sub>	M <sub>T</sub>	M <sub>u</sub>	M <sub>v</sub>
Querschnitt-Nr. 1: DUENQ ALUTECK40G									
1	LF1	MAX N	0.000	0.00	0.00	0.03	0.00	0.00	0.00
1	LF1	MIN N	0.000	0.00	0.00	0.03	0.00	0.00	0.00
1	LK2	MAX V <sub>y</sub>	0.000	0.00	0.06	1.33	0.00	0.00	0.00
1	LK1	MIN V <sub>y</sub>	2.150	0.00	-0.07	-1.44	0.00	-0.22	0.01
1	LK2	MAX V <sub>z</sub>	0.000	0.00	0.06	1.33	0.00	0.00	0.00
1	LK1	MIN V <sub>z</sub>	2.150	0.00	-0.07	-1.44	0.00	-0.22	0.01
1	LF1	MAX M <sub>T</sub>	0.000	0.00	0.00	0.03	0.00	0.00	0.00
1	LF1	MIN M <sub>T</sub>	0.000	0.00	0.00	0.03	0.00	0.00	0.00
1	LK2	MAX M <sub>y</sub>	1.075	0.00	0.00	0.00	0.00	0.71	-0.03
1	LK1	MIN M <sub>y</sub>	2.150	0.00	-0.07	-1.44	0.00	-0.22	0.01
1	LK1	MAX M <sub>z</sub>	2.150	0.00	-0.07	-1.44	0.00	-0.22	0.01
1	LK2	MIN M <sub>z</sub>	1.075	0.00	0.00	0.00	0.00	0.71	-0.03



Projekt: 6168 AluTeck 40G

2.2

Projekt:

Modell: 2.2 Einfeld mit Kragarm

Datum:

21.05.2024

■ SCHNITTGRÖSSEN  $M_y$ , LK1: 1.35\*LF1 + 1.5\*LF2

LK2 : 1.35\*LF1 + 1.5\*LF3  
Schnittgrößen M-u

Isometrie

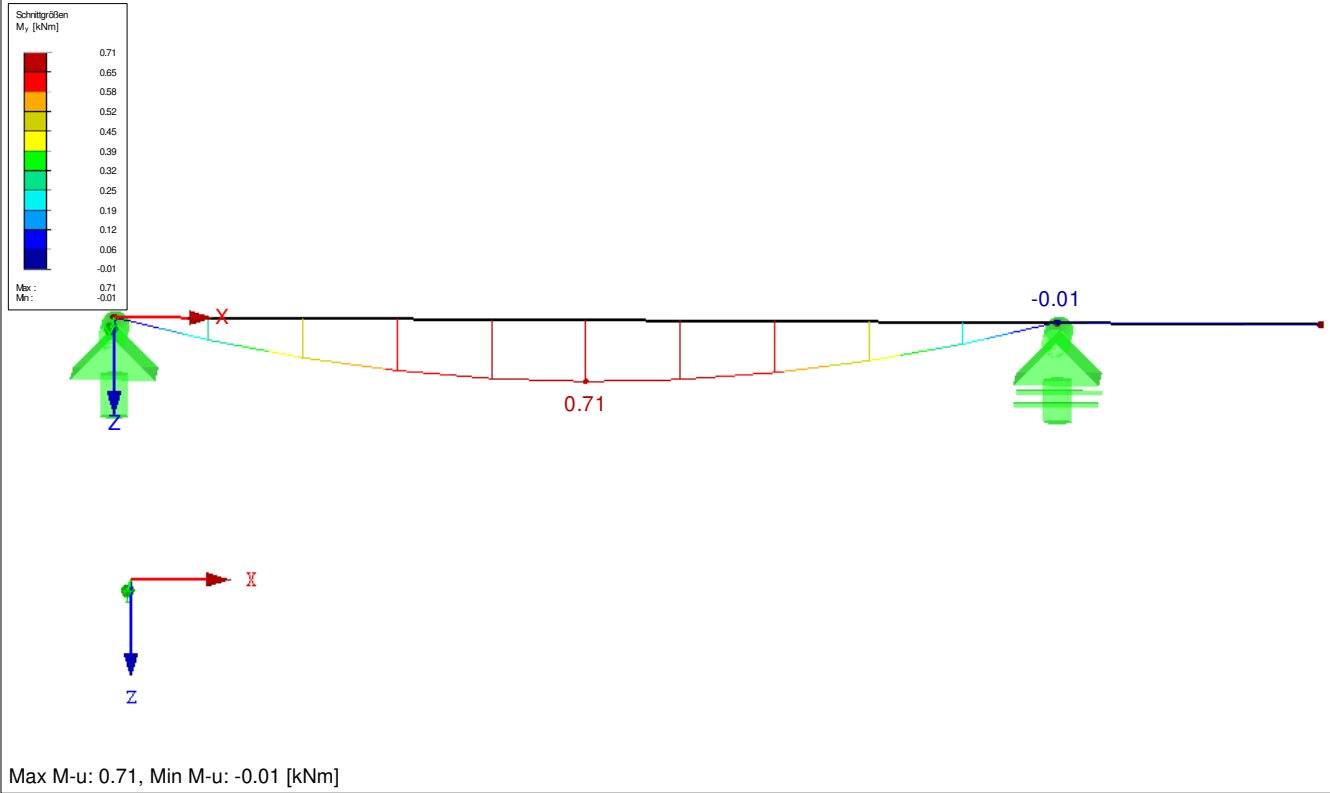

■ GLOBALE VERFORMUNGEN u

LK5 : LF1 + LF3  
Globale Verformungen u [mm]

Isometrie

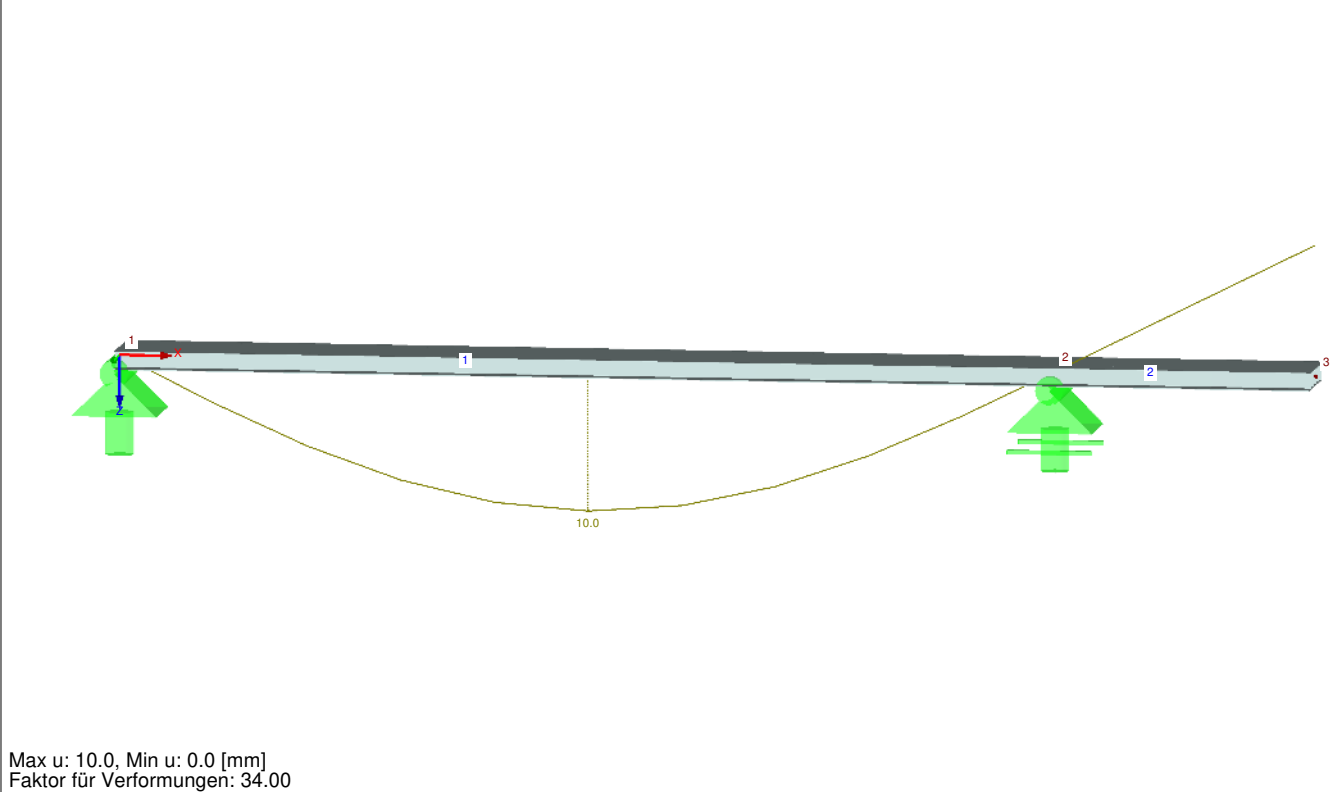



Projekt: 6168 AluTeck 40G

2.2

Projekt:

Modell: 2.2 Einfeld mit Kragarm

Datum:

21.05.2024

■ GLOBALE VERFORMUNGEN u

LK6 : LF1 + LF4

Globale Verformungen u [mm]

Isometrie

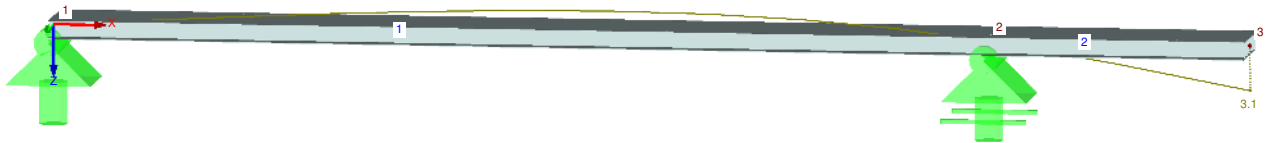

Max u: 3.1, Min u: 0.0 [mm]  
Faktor für Verformungen: 34.00



### 3.0 Zweifeldträger l = 2,45m

#### System:



#### Belastung:

Eigengew. Profile: aus EDV- Berechnung

Nutzlast: Die Nutzlast wird auf 5 Dielen je Meter verlegte Elemente verteilt

$$p = 4,0 / 5 = 0,8 \text{ kN/m}$$

Gebrauchstauglichkeit: Begrenzung Verformung  $\leq l / 200$

$$u = 1,18 \text{ cm} = l/208$$

Tragfähigkeit:  $M_{Ed} = 0,93 \text{ kNm}$

$$W = 16,47 \text{ cm}^3$$

$$\sigma = 0,93 \times 100 / 16,47 = 5,6 \text{ kN/cm}^2 < 24,5 / 1,25 = 19,6 \text{ kN/cm}^2$$

Die Spannweite ist als Grenzspannweite festgelegt. Kürzere Spannweiten sind möglich.



Projekt: 6168 AluTeck 40G

3.0

Projekt: Modell: 3.0 Zweifeld Datum: 21.05.2024

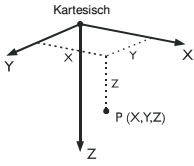

1.1 KNOTEN

Knoten Nr.	Bezugs-Knoten	Koordinaten-System	Knotenkoordinaten			Kommentar
			X [m]	Y [m]	Z [m]	
1	-	Kartesisch	0.000	0.000	0.000	Abgestützt
2	-	Kartesisch	2.450	0.000	0.000	Abgestützt
3	-	Kartesisch	4.900	0.000	0.000	Abgestützt

MODELL

LF1 : ständige Last

Isometrie

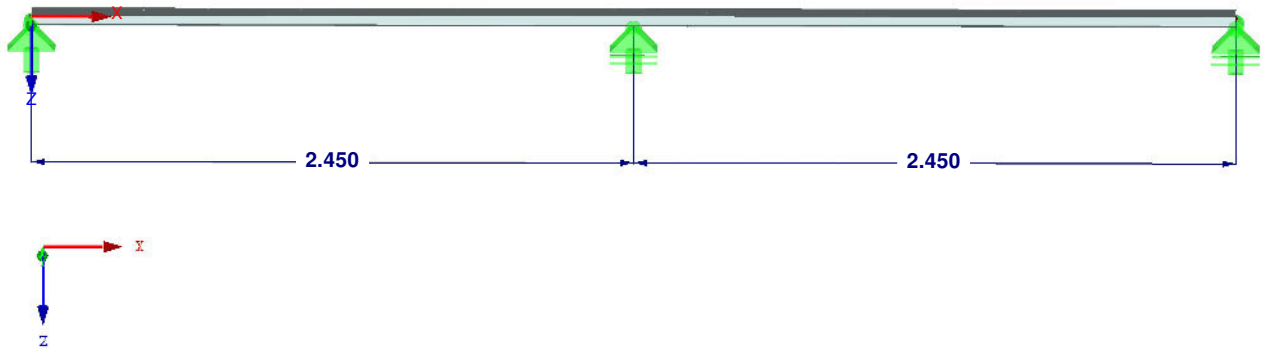

1.2 MATERIALIEN

Mat. Nr.	Modul E [kN/cm <sup>2</sup> ]	Modul G [kN/cm <sup>2</sup> ]	Spez. Gewicht $\gamma$ [kN/m <sup>3</sup> ]	Wärmedehn. $\alpha$ [1/K]	Teilsich.-Beiwert $\gamma_M$ [-]	Material-Modell
1	Aluminium EN-AW 6063 (DT) T66   EN 1999-1-1:2007 7000.00	2700.00	27.00	2.30E-05	1.00	Isotrop linear elastisch

1.3 QUERSCHNITTE



Quers. Nr.	Mater. Nr.	I <sub>r</sub> [cm <sup>4</sup> ]	I <sub>y</sub> [cm <sup>4</sup> ]	I <sub>z</sub> [cm <sup>4</sup> ]	Hauptachsen $\alpha$ [°]	Drehung $\alpha'$ [°]	Gesamtabmessungen [mm]	
							Breite b	Höhe h
1	DUENQ ALUTECK40G 1	75.89 11.80	32.66 6.78	414.96 3.17	2.68	0.00	228.0	40.0

1.7 STÄBE

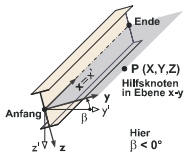

Stab Nr.	Stabtyp	Knoten		Drehung		Querschnitt		Gelenk Nr.		Exz. Nr.	Teilung Nr.	Länge L [m]	
		Anfang	Ende	Typ	$\beta$ [°]	Anfang	Ende	Anfang	Ende				
1	Balkenstab	1	2	Winkel	0.00	1	1	-	-	-	-	2.450	X
2	Balkenstab	2	3	Winkel	0.00	1	1	-	-	-	-	2.450	X

1.8 KNOTENLAGER

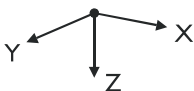

Lager Nr.	Knoten Nr.	Folge	Lagerdrehung [°]			Stütze in Z	Lagerung bzw. Feder					
			um X	um Y	um Z		u <sub>x</sub>	u <sub>y</sub>	u <sub>z</sub>	$\phi_x$	$\phi_y$	$\phi_z$
1	1	XYZ	0.00	0.00	0.00	<input type="checkbox"/>	<input checked="" type="checkbox"/>	<input checked="" type="checkbox"/>	<input checked="" type="checkbox"/>	<input checked="" type="checkbox"/>	<input type="checkbox"/>	<input type="checkbox"/>
2	2,3	XYZ	0.00	0.00	0.00	<input type="checkbox"/>	<input type="checkbox"/>	<input checked="" type="checkbox"/>	<input checked="" type="checkbox"/>	<input checked="" type="checkbox"/>	<input type="checkbox"/>	<input type="checkbox"/>



Projekt: 6168 AluTeck 40G

3.0

Projekt: Modell: 3.0 Zweifeld Datum: 21.05.2024

2.1 LASTFÄLLE

Lastfall	LF-Bezeichnung	Keine Norm Einwirkungskategorie	Eigengewicht - Faktor in Richtung			
			Aktiv	X	Y	Z
LF1	ständige Last	Ständige Lasten	<input checked="" type="checkbox"/>	0.000	0.000	1.000
LF2	Nutzlast Vollast	Nutzlasten	<input type="checkbox"/>			
LF3	Nutzlast Feld 1	Nutzlasten	<input type="checkbox"/>			
LF4	Nutzlast Feld 2	Nutzlasten	<input type="checkbox"/>			

2.5 LASTKOMBINATIONEN

Lastkombin.	BS	Lastkombination Bezeichnung	Nr.	Faktor	Lastfall	
					Nr.	Bezeichnung
LK1		1.35*LF1 + 1.5*LF2	1	1.35	LF1	ständige Last
			2	1.50	LF2	Nutzlast Vollast
LK2		1.35*LF1 + 1.5*LF3	1	1.35	LF1	ständige Last
			2	1.50	LF3	Nutzlast Feld 1
LK3		1.35*LF1 + 1.5*LF4	1	1.35	LF1	ständige Last
			2	1.50	LF4	Nutzlast Feld 2
LK4		LF1 + LF2	1	1.00	LF1	ständige Last
			2	1.00	LF2	Nutzlast Vollast
LK5		LF1 + LF3	1	1.00	LF1	ständige Last
			2	1.00	LF3	Nutzlast Feld 1
LK6		LF1 + LF4	1	1.00	LF1	ständige Last
			2	1.00	LF4	Nutzlast Feld 2

LAGERREAKTIONEN, LF1

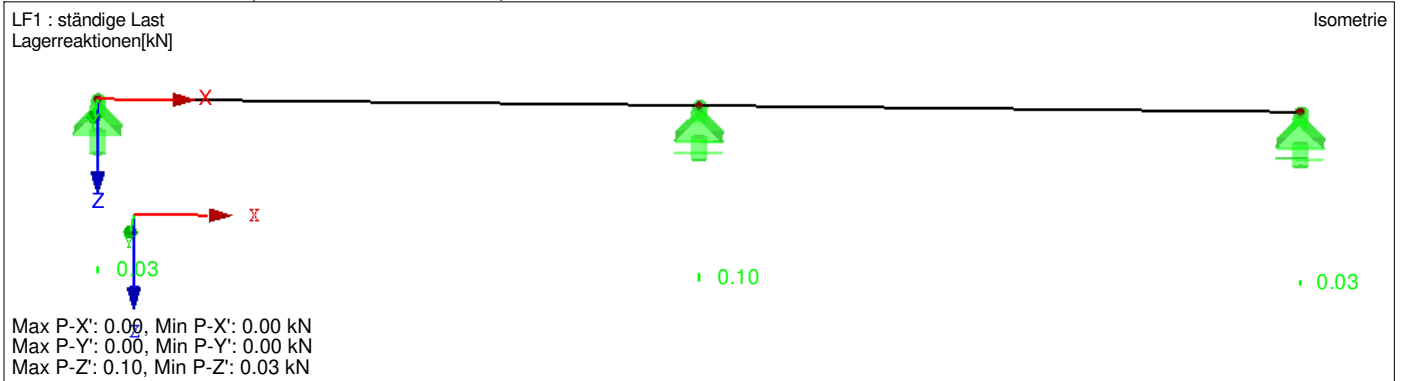

3.2 STABLASTEN

LF2: Nutzlast Vollast

Nr.	Beziehen auf	An Stäben Nr.	Last-Art	Last-Verteilung	Last-Richtung	Bezugs-Länge	Lastparameter		
							Symbol	Wert	Einheit
1	Stäbe	1,2	Kraft	Konstant	Z	Wahre Länge	p	0.800	kN/m

LAGERREAKTIONEN, LF2

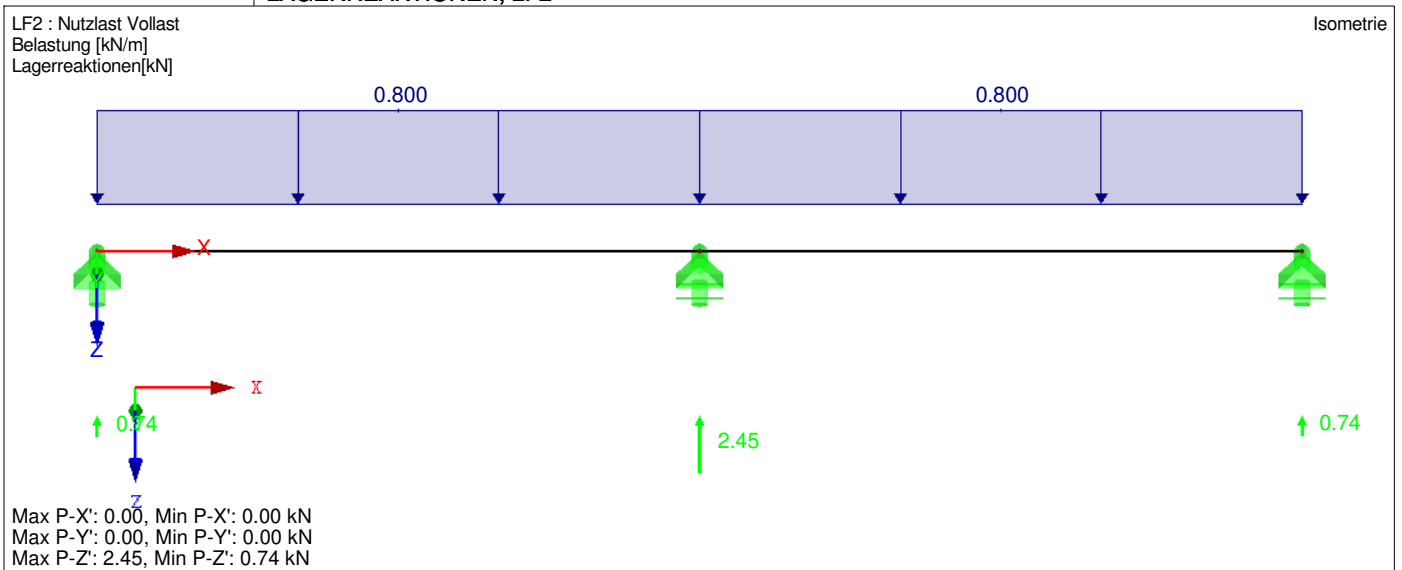



Projekt: 6168 AluTeck 40G

3.0

Projekt:

Modell: 3.0 Zweifeld

Datum:

21.05.2024

LF3  
Nutzlast Feld 1

3.2 STABLASTEN

LF3: Nutzlast Feld 1

Nr.	Beziehen auf	An Stäben Nr.	Last-Art	Last-verteilung	Last-Richtung	Bezugs-Länge	Symbol	Lastparameter	
1	Stäbe	1	Kraft	Konstant	Z	Wahre Länge	p	Wert	Einheit
								0.800	kN/m

LAGERREAKTIONEN

LF3 : Nutzlast Feld 1  
Belastung [kN/m]  
Lagerreaktionen[kN]

Isometrie

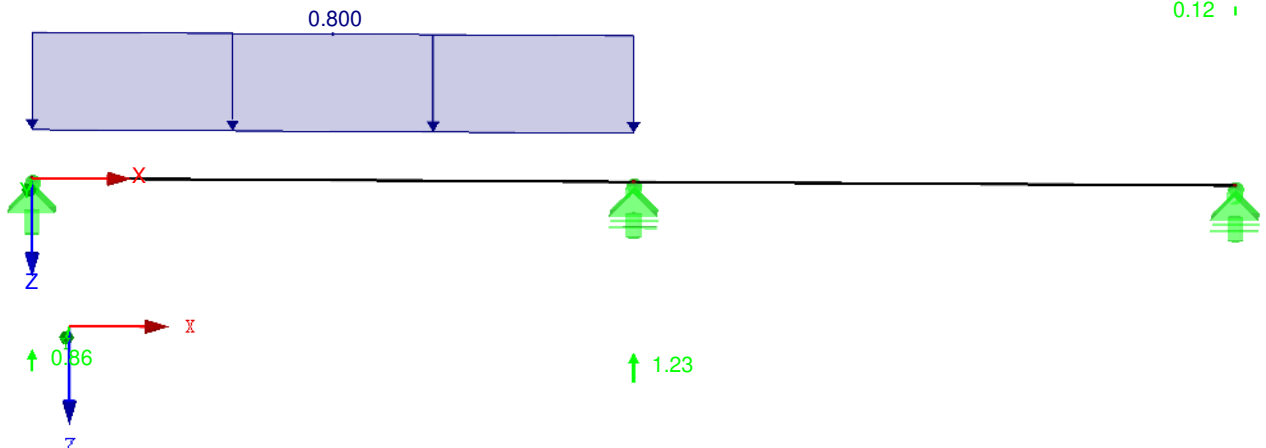

Max P-X': 0.00, Min P-X': 0.00 kN  
Max P-Y': 0.00, Min P-Y': 0.00 kN  
Max P-Z': 1.23, Min P-Z': -0.12 kN

LF4  
Nutzlast Feld 2

3.2 STABLASTEN

LF4: Nutzlast Feld 2

Nr.	Beziehen auf	An Stäben Nr.	Last-Art	Last-verteilung	Last-Richtung	Bezugs-Länge	Symbol	Lastparameter	
1	Stäbe	2	Kraft	Konstant	Z	Wahre Länge	p	Wert	Einheit
								0.800	kN/m

LAGERREAKTIONEN

LF4 : Nutzlast Feld 2  
Belastung [kN/m]  
Lagerreaktionen[kN]

Isometrie

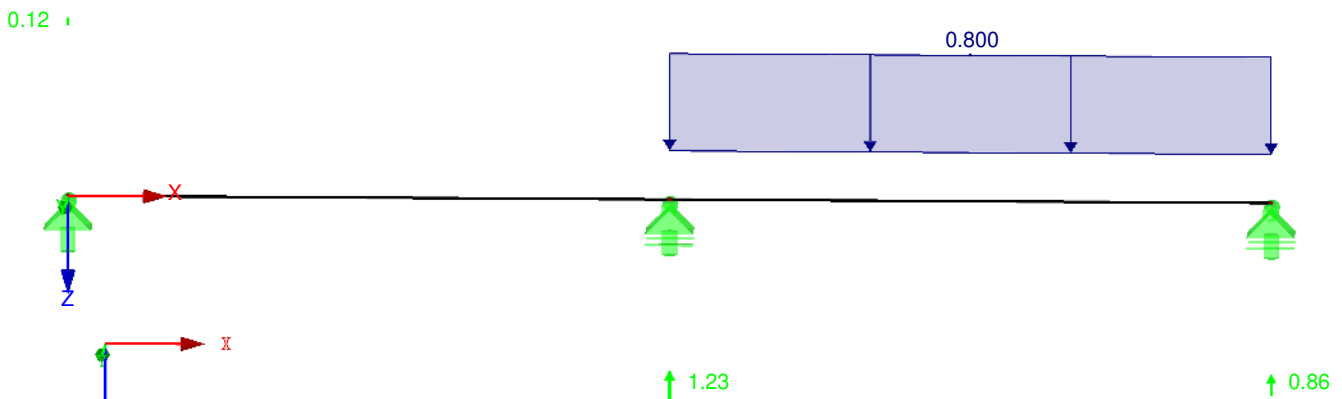

Max P-X': 0.00, Min P-X': 0.00 kN  
Max P-Y': 0.00, Min P-Y': 0.00 kN  
Max P-Z': 1.23, Min P-Z': -0.12 kN

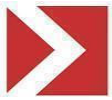

Projekt: 6168 AluTeck 40G

3.0

Projekt:

Modell: 3.0 Zweifeld

Datum:

21.05.2024

4.3 QUERSCHNITTE - SCHNITTGRÖSSEN

Stab Nr.	LF/LK	Knoten Nr.	Stelle x [m]	Kräfte [kN]			Momente [kNm]				
				N	V <sub>u</sub>	V <sub>v</sub>	M <sub>T</sub>	M <sub>u</sub>	M <sub>v</sub>		
Querschnitt-Nr. 1: DUENQ ALUTECK40G											
1	LF1	MAX N	0.000	0.00	0.00	0.03	0.00	0.00	0.00	0.00	0.00
1	LF1	MIN N	0.000	0.00	0.00	0.03	0.00	0.00	0.00	0.00	0.00
2	LK1	MAX V <sub>y</sub>	0.000	0.00	0.09	1.90	0.00	-0.93	0.04	0.04	0.04
1	LK1	MIN V <sub>y</sub>	2.450	0.00	-0.09	-1.90	0.00	-0.93	0.04	0.04	0.04
2	LK1	MAX V <sub>z</sub>	0.000	0.00	0.09	1.90	0.00	-0.93	0.04	0.04	0.04
1	LK1	MIN V <sub>z</sub>	2.450	0.00	-0.09	-1.90	0.00	-0.93	0.04	0.04	0.04
1	LF1	MAX M <sub>T</sub>	0.000	0.00	0.00	0.03	0.00	0.00	0.00	0.00	0.00
1	LF1	MIN M <sub>T</sub>	0.000	0.00	0.00	0.03	0.00	0.00	0.00	0.00	0.00
2	LK3	MAX M <sub>y</sub>	1.348	0.00	0.00	0.04	0.00	0.71	-0.03	-0.03	-0.03
1	LK1	MIN M <sub>y</sub>	2.450	0.00	-0.09	-1.90	0.00	-0.93	0.04	0.04	0.04
1	LK1	MAX M <sub>z</sub>	2.450	0.00	-0.09	-1.90	0.00	-0.93	0.04	0.04	0.04
1	LK2	MIN M <sub>z</sub>	1.103	0.00	0.00	-0.04	0.00	0.71	-0.03	-0.03	-0.03





Projekt: 6168 AluTeck 40G

3.0

Projekt:

Modell: 3.0 Zweifeld

Datum:

21.05.2024

■ SCHNITTGRÖSSEN  $M_y$ , LK1: 1.35\*LF1 + 1.5\*LF2

LK1 : 1.35\*LF1 + 1.5\*LF2  
Schnittgrößen M-u

Isometrie

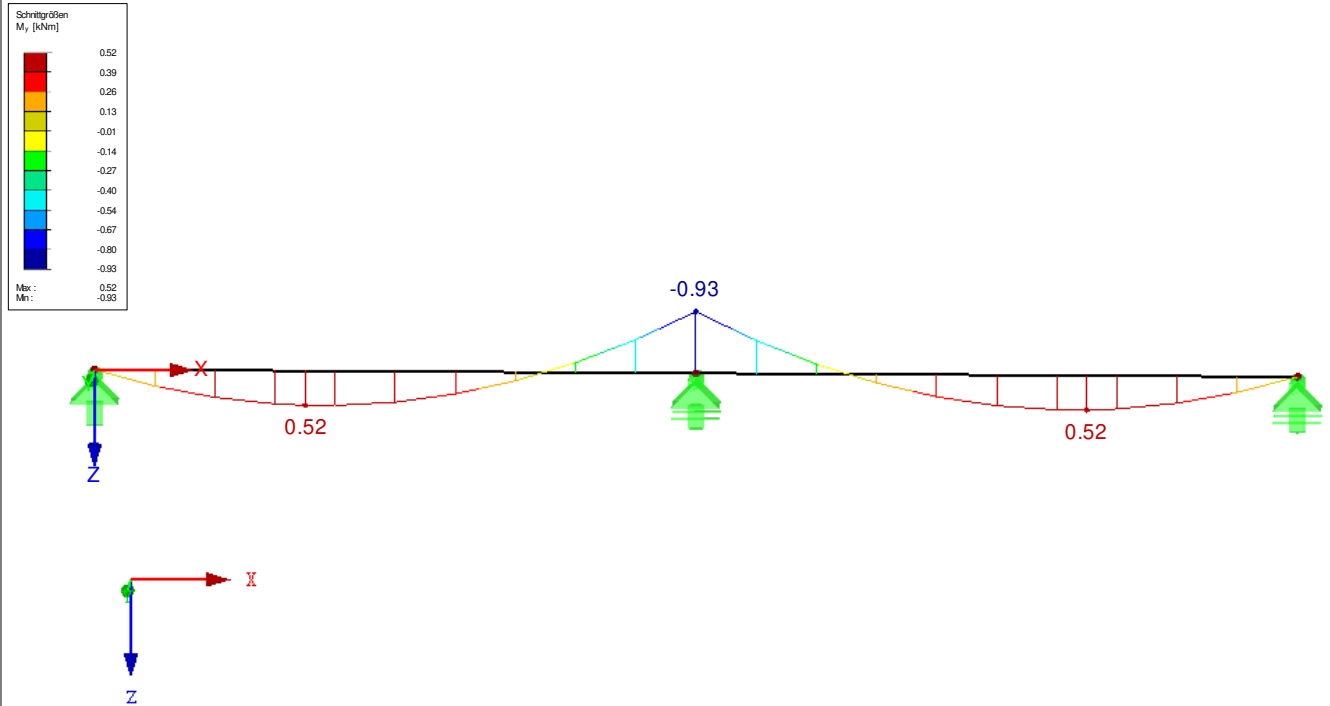

■ GLOBALE VERFORMUNGEN u

LK3 : 1.35\*LF1 + 1.5\*LF4  
Globale Verformungen u [mm]

Isometrie





### 4.0 Dreifeldträger I = 2,45m

#### System:

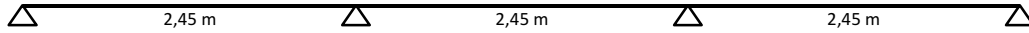

#### Belastung:

Eigengew. Profile: aus EDV- Berechnung

Nutzlast: Die Nutzlast wird auf 5 Dielen je Meter verlegte Elemente verteilt

$$p = 4,0 / 5 = 0,8 \text{ kN/m}^2$$

Gebrauchstauglichkeit: Begrenzung Verformung  $\leq l / 200$

$$u = 1,15 \text{ cm} = l/213$$

Tragfähigkeit:  $M_{Ed} = 0,75 \text{ kNm}$

$$W = 16,47 \text{ cm}^3$$

$$\sigma = 0,75 \times 100 / 16,47 = 4,6 \text{ kN/cm}^2 < 24,5 / 1,25 = 19,6 \text{ kN/cm}^2$$

Die Spannweite ist als Grenzspannweite festgelegt. Kürzere Spannweiten sind möglich.

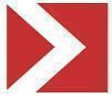

Projekt: 6168 AluTeck 40G

4.0

Projekt: Modell: 4.0 Dreifeld Datum: 21.05.2024

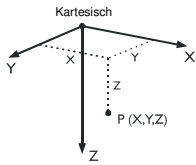

1.1 KNOTEN

Knoten Nr.	Bezugs-Knoten	Koordinaten-System	Knotenkoordinaten			Kommentar
			X [m]	Y [m]	Z [m]	
1	-	Kartesisch	0.000	0.000	0.000	Abgestützt
2	-	Kartesisch	2.450	0.000	0.000	Abgestützt
3	-	Kartesisch	4.900	0.000	0.000	Abgestützt
4	-	Kartesisch	7.350	0.000	0.000	Abgestützt

MODELL

LF1 : ständige Last

Isometrie

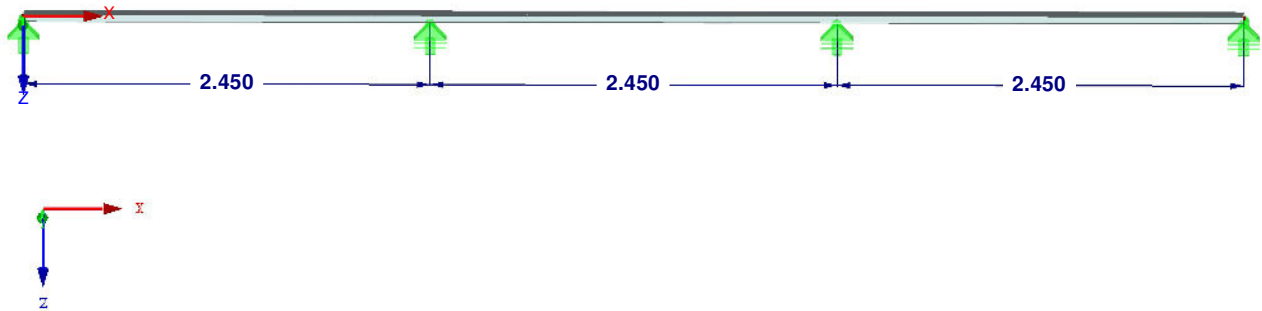

1.2 MATERIALIEN

Mat. Nr.	Modul E [kN/cm <sup>2</sup> ]	Modul G [kN/cm <sup>2</sup> ]	Spez. Gewicht $\gamma$ [kN/m <sup>3</sup> ]	Wärmedehnz. $\alpha$ [1/K]	Teilsich.-Beiwert $\gamma_M$ [-]	Material-Modell
1	Aluminium EN-AW 6063 (DT) T66   EN 1999-1-1:2007 7000.00	2700.00	27.00	2.30E-05	1.00	Isotrop linear elastisch

1.3 QUERSCHNITTE



Quers. Nr.	Mater. Nr.	$I_T$ [cm <sup>4</sup> ]		$I_U$ [cm <sup>4</sup> ]		$I_V$ [cm <sup>4</sup> ]		Hauptachsen $\alpha$ [°]	Drehung $\alpha'$ [°]	Gesamtabmessungen [mm]	
		A [cm <sup>2</sup> ]		$A_u$ [cm <sup>2</sup> ]		$A_v$ [cm <sup>2</sup> ]				Breite b	Höhe h
1	DUENQ ALUTECK40G 1	75.89 11.80		32.66 6.78		414.96 3.17		2.68	0.00	228.0	40.0

1.7 STÄBE

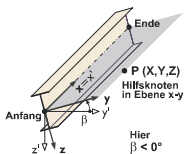

Stab Nr.	Stabtyp	Knoten		Drehung		Querschnitt		Gelenk Nr.		Exz. Nr.	Teilung Nr.	Länge L [m]	
		Anfang	Ende	Typ	$\beta$ [°]	Anfang	Ende	Anfang	Ende				
1	Balkenstab	1	2	Winkel	0.00	1	1	-	-	-	-	2.450	X
2	Balkenstab	2	3	Winkel	0.00	1	1	-	-	-	-	2.450	X
3	Balkenstab	3	4	Winkel	0.00	1	1	-	-	-	-	2.450	X

1.8 KNOTENLAGER

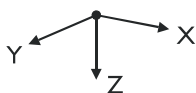

Lager Nr.	Knoten Nr.	Folge	Lagerdrehung [°]			Stütze in Z	Lagerung bzw. Feder					
			um X	um Y	um Z		$u_x$	$u_y$	$u_z$	$\phi_x$	$\phi_y$	$\phi_z$
1	1	XYZ	0.00	0.00	0.00	<input type="checkbox"/>	<input checked="" type="checkbox"/>	<input checked="" type="checkbox"/>	<input checked="" type="checkbox"/>	<input checked="" type="checkbox"/>	<input type="checkbox"/>	<input type="checkbox"/>
2	2-4	XYZ	0.00	0.00	0.00	<input type="checkbox"/>	<input type="checkbox"/>	<input checked="" type="checkbox"/>	<input checked="" type="checkbox"/>	<input checked="" type="checkbox"/>	<input type="checkbox"/>	<input type="checkbox"/>

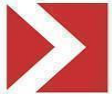

Projekt: 6168 AluTeck 40G

4.0

Projekt: Modell: 4.0 Dreifeld Datum: 21.05.2024

2.1 LASTFÄLLE

Lastfall	LF-Bezeichnung	Keine Norm Einwirkungskategorie	Aktiv	Eigengewicht - Faktor in Richtung		
				X	Y	Z
LF1	ständige Last	Ständige Lasten	<input checked="" type="checkbox"/>	0.000	0.000	1.000
LF2	Nutzlast Vollast	Nutzlasten	<input type="checkbox"/>			
LF3	Nutzlast Feld 1	Nutzlasten	<input type="checkbox"/>			
LF4	Nutzlast Feld 2	Nutzlasten	<input type="checkbox"/>			
LF5	Nutzlast Feld 3	Nutzlasten	<input type="checkbox"/>			

2.5 LASTKOMBINATIONEN

Lastkombin.	BS	Lastkombination Bezeichnung	Nr.	Faktor	Lastfall	
LK1		1.35*LF1 + 1.5*LF2	1	1.35	LF1	ständige Last
			2	1.50	LF2	Nutzlast Vollast
LK2		1.35*LF1 + 1.5*LF3	1	1.35	LF1	ständige Last
			2	1.50	LF3	Nutzlast Feld 1
LK3		1.35*LF1 + 1.5*LF4	1	1.35	LF1	ständige Last
			2	1.50	LF4	Nutzlast Feld 2
LK4		1.35*LF1 + 1.5*LF5	1	1.35	LF1	ständige Last
			2	1.50	LF5	Nutzlast Feld 3
LK5		1.35*LF1 + 1.5*LF6	1	1.35	LF1	ständige Last
			2	1.50	LF6	Nutzlast Feld 1 + 3
LK6		LF1 + LF2	1	1.00	LF1	ständige Last
			2	1.00	LF2	Nutzlast Vollast
LK7		LF1 + LF3	1	1.00	LF1	ständige Last
			2	1.00	LF3	Nutzlast Feld 1
LK8		LF1 + LF4	1	1.00	LF1	ständige Last
			2	1.00	LF4	Nutzlast Feld 2
LK9		LF1 + LF5	1	1.00	LF1	ständige Last
			2	1.00	LF5	Nutzlast Feld 3
LK10		LF1 + LF6	1	1.00	LF1	ständige Last
			2	1.00	LF6	Nutzlast Feld 1 + 3



Projekt: 6168 AluTeck 40G

4.0

Projekt:

Modell: 4.0 Dreifeld

Datum:

21.05.2024

LAGERREAKTIONEN, LF1

LF1 : ständige Last  
Lagerreaktionen[kN]

Isometrie

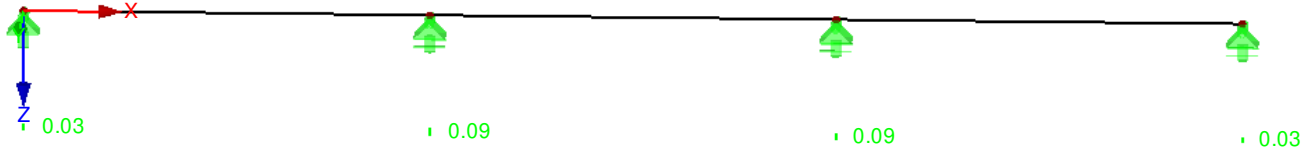

Max P-X: 0.00, Min P-X: 0.00 kN  
Max P-Y: 0.00, Min P-Y: 0.00 kN  
Max P-Z: 0.09, Min P-Z: 0.03 kN

3.2 STABLASTEN

LF2  
Nutzlast Vollast

LF2: Nutzlast Vollast

Nr.	Beziehen auf	An Stäben Nr.	Last-Art	Last-Verteilung	Last-Richtung	Bezugs-Länge	Lastparameter		
							Symbol	Wert	Einheit
1	Stäbe	1-3	Kraft	Konstant	Z	Wahre Länge	p	0.800	kN/m

LAGERREAKTIONEN, LF2

LF2 : Nutzlast Vollast  
Belastung [kN/m]  
Lagerreaktionen[kN]

Isometrie

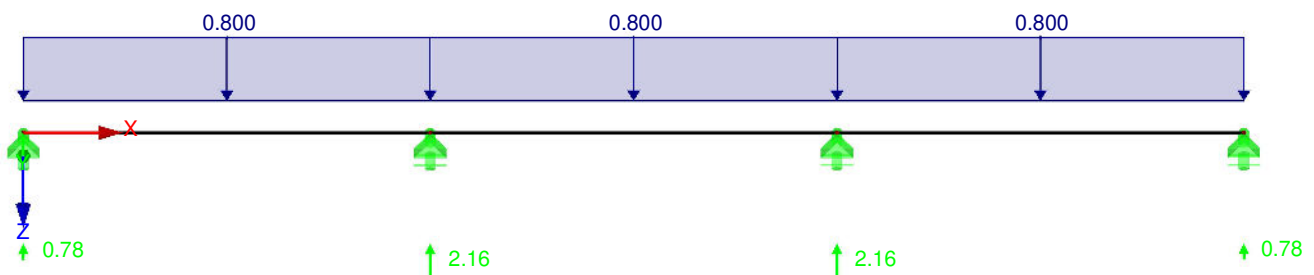

Max P-X: 0.00, Min P-X: 0.00 kN  
Max P-Y: 0.00, Min P-Y: 0.00 kN  
Max P-Z: 2.16, Min P-Z: 0.78 kN



Projekt: 6168 AluTeck 40G

4.0

Projekt:

Modell: 4.0 Dreifeld

Datum:

21.05.2024

LF3  
Nutzlast Feld 1

3.2 STABLASTEN

LF3: Nutzlast Feld 1

Nr.	Beziehen auf	An Stäben Nr.	Last-Art	Last-Verteilung	Last-Richtung	Bezugs-Länge	Symbol	Lastparameter Wert	Einheit
1	Stäbe	1	Kraft	Konstant	Z	Wahre Länge	p	0.800	kN/m

LAGERREAKTIONEN

LF3 : Nutzlast Feld 1  
Belastung [kN/m]  
Lagerreaktionen[kN]

Isometrie

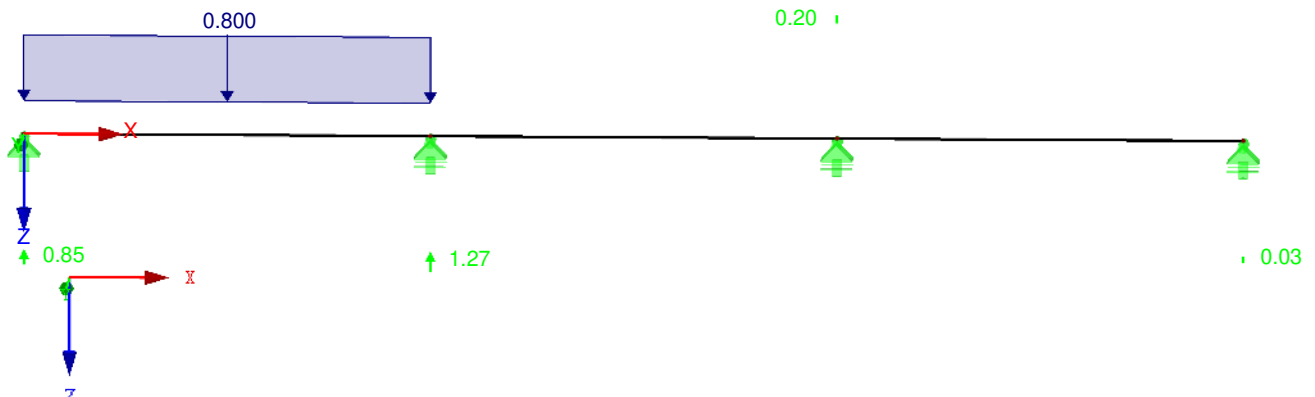

Max P-X': 0.00, Min P-X': 0.00 kN  
Max P-Y': 0.00, Min P-Y': 0.00 kN  
Max P-Z': 1.27, Min P-Z': -0.20 kN

LF4  
Nutzlast Feld 2

3.2 STABLASTEN

LF4: Nutzlast Feld 2

Nr.	Beziehen auf	An Stäben Nr.	Last-Art	Last-Verteilung	Last-Richtung	Bezugs-Länge	Symbol	Lastparameter Wert	Einheit
1	Stäbe	2	Kraft	Konstant	Z	Wahre Länge	p	0.800	kN/m

LAGERREAKTIONEN

LF4 : Nutzlast Feld 2  
Belastung [kN/m]  
Lagerreaktionen[kN]

Isometrie

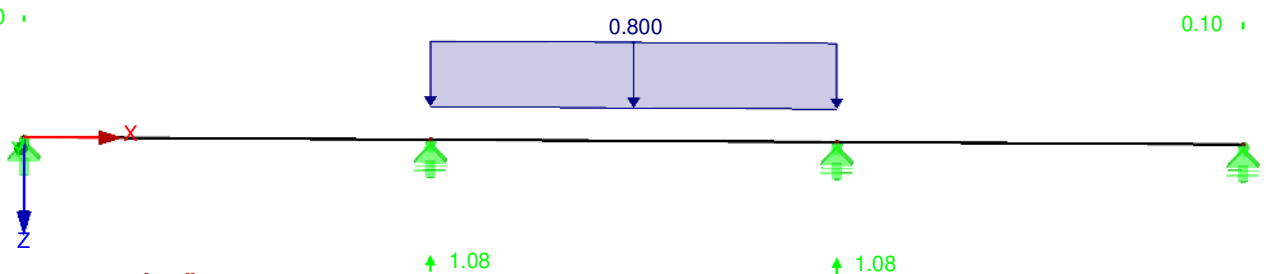

Max P-X': 0.00, Min P-X': 0.00 kN  
Max P-Y': 0.00, Min P-Y': 0.00 kN  
Max P-Z': 1.08, Min P-Z': -0.10 kN



Projekt: 6168 AluTeck 40G

4.0

Projekt: Modell: 4.0 Dreifeld Datum: 21.05.2024

LF5  
Nutzlast Feld 3

3.2 STABLASTEN

LF5: Nutzlast Feld 3

Nr.	Beziehen auf	An Stäben Nr.	Last-Art	Last-verteilung	Last-Richtung	Bezugs-Länge	Symbol	Lastparameter Wert	Einheit
1	Stäbe	3	Kraft	Konstant	Z	Wahre Länge	p	0.800	kN/m

LAGERREAKTIONEN-

LF5 : Nutzlast Feld 3  
Belastung [kN/m]  
Lagerreaktionen[kN]

Isometrie

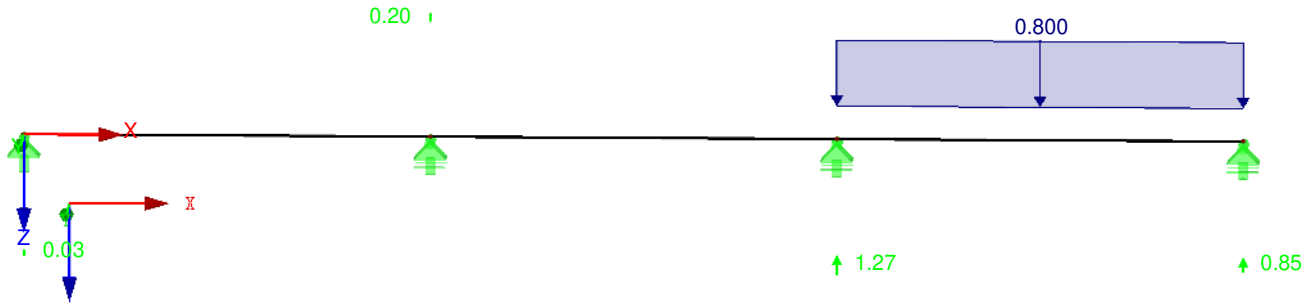

Max P-X': 0.00, Min P-X': 0.00 kN  
Max P-Y': 0.00, Min P-Y': 0.00 kN  
Max P-Z': 1.27, Min P-Z': -0.20 kN

LF6  
Nutzlast Feld 1 + 3

3.2 STABLASTEN

LF6: Nutzlast Feld 1 + 3

Nr.	Beziehen auf	An Stäben Nr.	Last-Art	Last-verteilung	Last-Richtung	Bezugs-Länge	Symbol	Lastparameter Wert	Einheit
1	Stäbe	1,3	Kraft	Konstant	Z	Wahre Länge	p	0.800	kN/m

LAGERREAKTIONEN

LF6 : Nutzlast Feld 1 + 3  
Belastung [kN/m]  
Lagerreaktionen[kN]

Isometrie

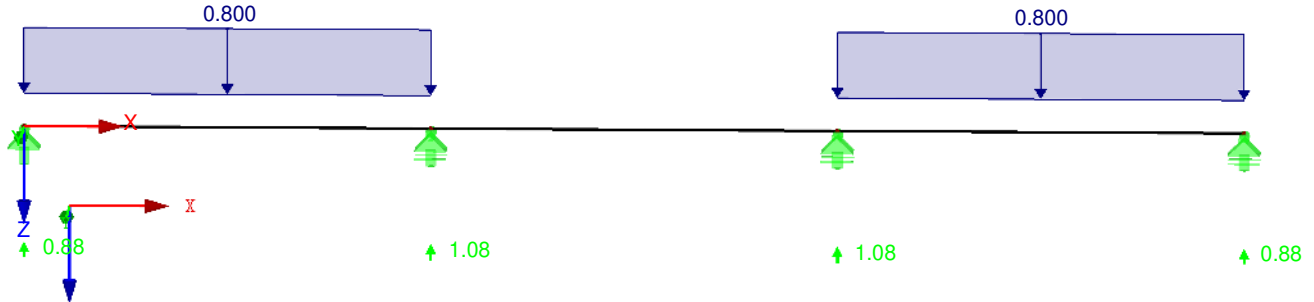

Max P-X': 0.00, Min P-X': 0.00 kN  
Max P-Y': 0.00, Min P-Y': 0.00 kN  
Max P-Z': 1.08, Min P-Z': 0.88 kN

4.3 QUERSCHNITTE - SCHNITTGRÖSSEN

Stab Nr.	LF/LK	Knoten Nr.	Stelle x [m]	Kräfte [kN]			Momente [kNm]		
				N	V <sub>u</sub>	V <sub>v</sub>	M <sub>T</sub>	M <sub>u</sub>	M <sub>v</sub>
Querschnitt-Nr. 1: DUENQ ALUTECK40G									
1	LF1	MAX N	0.000	0.00	0.00	0.03	0.00	0.00	0.00
1	LF1	MIN N	0.000	0.00	0.00	0.03	0.00	0.00	0.00
3	LK1	MAX V <sub>y</sub>	0.000	0.00	0.09	1.83	0.00	-0.75	0.03
1	LK1	MIN V <sub>y</sub>	2.450	0.00	-0.09	-1.83	0.00	-0.75	0.03
3	LK1	MAX V <sub>z</sub>	0.000	0.00	0.09	1.83	0.00	-0.75	0.03
1	LK1	MIN V <sub>z</sub>	2.450	0.00	-0.09	-1.83	0.00	-0.75	0.03
1	LF1	MAX M <sub>T</sub>	0.000	0.00	0.00	0.03	0.00	0.00	0.00
1	LF1	MIN M <sub>T</sub>	0.000	0.00	0.00	0.03	0.00	0.00	0.00
1	LK5	MAX M <sub>y</sub>	1.103	0.00	0.00	-0.01	0.00	0.75	-0.04
1	LK1	MIN M <sub>y</sub>	2.450	0.00	-0.09	-1.83	0.00	-0.75	0.03
1	LK1	MAX M <sub>z</sub>	2.450	0.00	-0.09	-1.83	0.00	-0.75	0.03
1	LK5	MIN M <sub>z</sub>	1.103	0.00	0.00	-0.01	0.00	0.75	-0.04



Projekt: 6168 AluTeck 40G

4.0

Projekt:

Modell: 4.0 Dreifeld

Datum:

21.05.2024

■ SCHNITTGRÖSSEN  $M_y$ , LK1: 1.35\*LF1 + 1.5\*LF2

LK1 : 1.35\*LF1 + 1.5\*LF2  
Schnittgrößen M-u

Isometrie

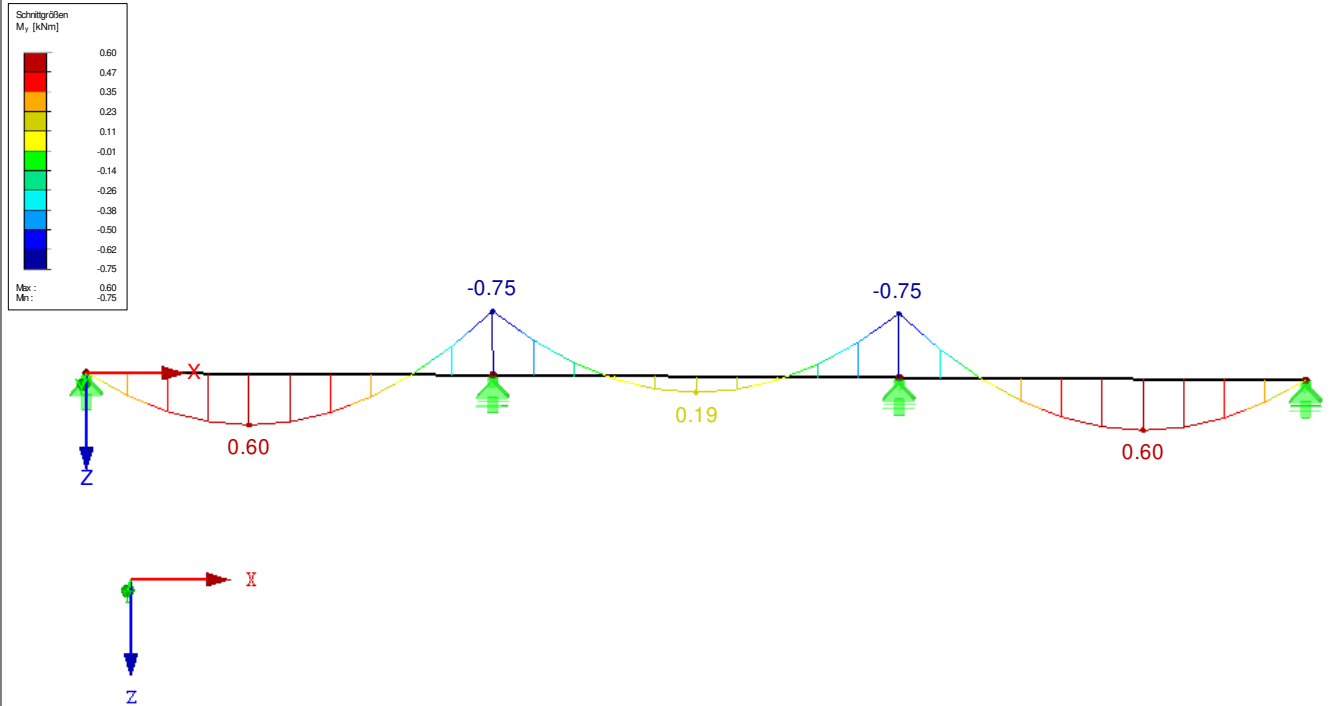

Max M-u: 0.60, Min M-u: -0.75 [kNm]

■ GLOBALE VERFORMUNGEN u

LK10 : LF1 + LF6  
Globale Verformungen u [mm]

Isometrie

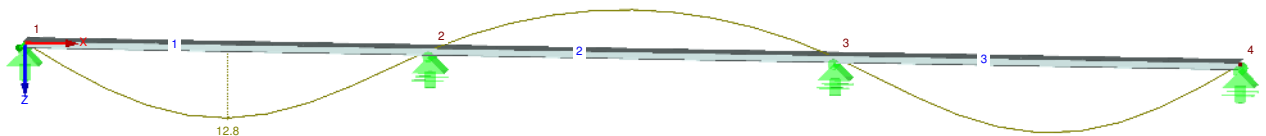

Max u: 12.8, Min u: 0.0 [mm]  
Faktor für Verformungen: 34.00





Hiermit ist die statische Berechnung zur Bemessung

**Aluminium Dielenbelag AluTeck 40G**

für

**AluTeck**

abgeschlossen.

Herbolzheim, 21.05.2024

Aufgestellt:

  
Dipl.-Ing Florian Kirchenbauer

